

**IN THE COURT OF APPEALS OF THE  
STATE OF OREGON**

In the Matter of:

RENEWABLE ENERGY COALITION,  
NORTHWEST & INTERMOUNTAIN  
POWER PRODUCERS COALITION,  
COMMUNITY RENEWABLE ENERGY  
ASSOCIATION and OREGON SOLAR  
ENERGY INDUSTRIES  
ASSOCIATION,

Petitioners,

v.

THE OREGON PUBLIC UTILITY  
COMMISSION,

Respondent,

and

PACIFICORP,

Applicant-Respondent

Oregon Public Utility Commission  
Docket No. UM 2108

CA No. A

**PETITION FOR JUDICIAL REVIEW**

Petitioners Renewable Energy Coalition, Northwest & Intermountain Power Producers Coalition, Community Renewable Energy Association, and Oregon Solar Energy Industries Association seek judicial review of the final orders of the Oregon Public Utility Commission in docket no. UM 2108, including Order No. 20-465, dated December 4, 2020, which denied rehearing and/or reconsideration of Order No. 20-268, dated August 19, 2020.

**RECEIVED**

FEB 01 2021

PETITION FOR JUDICIAL REVIEW

APPELLATE DIVISION  
SALEM, OR 97301

Page 1 of 6

The parties to the judicial review proceeding before the Court of Appeals are:

Petitioners:

Renewable Energy Coalition  
c/o John Lowe  
88644 Hwy. 101  
Gearhart, OR 97138

Northwest & Intermountain Power Producers Coalition  
c/o Spencer Gray  
P.O. Box 504  
Mercer Island, WA 98040

Oregon Solar Energy Industries Association  
c/o Angela Crowley-Koch  
P.O. Box 14927  
Portland, OR 97293

Community Renewable Energy Association  
c/o Gregory M. Adams  
P.O. Box 7218  
Boise, ID 83702

Respondents:

Oregon Public Utility Commission  
P.O. Box 1088  
Salem, OR 97308

PacifiCorp, dba Pacific Power  
825 NE Multnomah St, Ste 2000  
Portland OR 97232

Additionally, the following parties participated in the proceeding below:

Dalreed Solar  
c/o Ros Rocco Vrba  
P.O. Box 900083  
Sandy, UT 84090

NewSun Energy, LLC  
c/o Marie P. Barlow

390 SW Columbia St Ste 120  
Bend, OR 97702

Petitioners Renewable Energy Coalition, Northwest & Intermountain Power  
Producers Coalition, and Oregon Solar Energy Industries Association are represented by:

Irion A. Sanger, OSB #003750  
irion@sanger-law.com  
Joni Sliger, OSB #180422  
joni@sanger-law.com  
Sanger Law, PC  
1041 SE 58th Place  
Portland, OR 97215  
(503) 756-7533

Petitioner Community Renewable Energy Association is represented by:

Gregory M. Adams, OSB No. 101779  
greg@richardsonadams.com  
Richardson Adams, PLLC  
515 N. 27th Street  
Boise, ID 83702  
(208) 938-2236

Respondent Oregon Public Utility Commission is represented by:

Stephanie S. Andrus, OSB #925123  
stephanie.andrus@state.or.us  
Oregon Department of Justice  
Business Activities Section  
1162 Court St. NE  
Salem, OR 97301-4096

and

Attorney General of the State of Oregon  
Office of the Solicitor General  
400 Justice Building  
1162 Court Street NE  
Salem, Oregon 97301-4096

Respondent PacifiCorp is represented by:

Karen Kruse, OSB #112733  
PacifiCorp  
karen.kruse@pacificorp.com  
825 NE Multnomah Ste 2000  
Portland, OR 97232

and

Adam Lowney, OSB #053124  
McDowell Rackner & Gibson PC  
adam@mrg-law.com  
419 SW 11th Ave, Ste 400  
Portland OR 97205

Attached to this petition is a copy of each of the orders for which judicial review is sought. Order No. 20-268 approved with modifications Applicant-Respondent's application for reform of the procedures by which it is authorized by the Public Utility Commission to administer and process requests from small renewable energy generators to interconnect to its electrical system. Order No. 20-465 denied Petitioners' applications for rehearing and/or reconsideration of Order No. 20-268.

Petitioners Renewable Energy Coalition, Northwest & Intermountain Power Producers Coalition, Community Renewable Energy Association, and Oregon Solar Energy Industries Association contend they each were parties to the administrative proceeding which resulted in the orders for which review is sought. Each of the Petitioners submitted stakeholder comments in response to the application before the Public Utility Commission, and each of the Petitioners filed an application for reconsideration of Order No. 20-268. However, the Public Utility Commission did not affirmatively rule on petitions to intervene filed in the proceeding below. Therefore, in

the alternative, to the extent that Petitioners could be deemed to have not been parties to the proceeding, Petitioners seek judicial review as persons adversely affected or aggrieved by the orders and submit supporting affidavits with this Petition.

Petitioners are not willing to stipulate that the agency record may be shortened at this time.

Dated this 29th day of January 2021.

Respectfully submitted,

SANGER LAW, PC

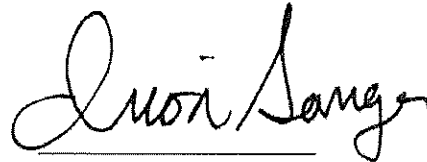

Irion A. Sanger, OSB #003750

irion@sanger-law.com

Joni Sliger, OSB #180422

joni@sanger-law.com

Sanger Law, PC

1041 SE 58th Place

Portland, OR 97215

Telephone: 503-756-7533

Fax: 503-334-2235

irion@sanger-law.com

joni@sanger-law.com

Of Attorneys for Petitioners  
Renewable Energy Coalition, Northwest &  
Intermountain Power Producers Coalition,  
and Oregon Solar Energy Industries  
Association

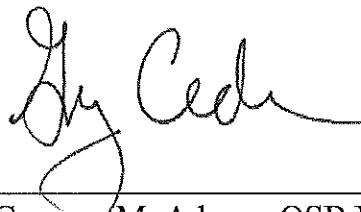

---

Gregory M. Adams, OSB No. 101779  
greg@richardsonadams.com  
Richardson Adams, PLLC  
515 N. 27th Street  
Boise, ID 83702  
(208) 938-2236

Attorney for the Community Renewable  
Energy Association

## CERTIFICATE OF SERVICE

I certify that I served a copy of the foregoing **PETITION FOR JUDICIAL REVIEW** on all of the following:

Adam Lowney, OSB #053124  
McDowell Rackner & Gibson PC  
419 SW 11th Ave, Ste 400  
Portland OR 97205

Oregon Public Utility Commission  
Stephanie S. Andrus, OSB #925123  
Oregon Department of Justice  
Business Activities Section  
1162 Court St. NE  
Salem, OR 97301-4096

Karen Kruse, OSB #112733  
825 NE Multnomah Ste 2000  
Portland OR 97232  
karen.kruse@pacificcorp.com

Attorney General of the State of Oregon  
Office of the Solicitor General  
400 Justice Building  
1162 Court Street NE  
Salem, Oregon 97301-4096

Dalreed Solar  
c/o Ros Rocco Vrba  
P.O. Box 900083  
Sandy, UT 84090

NewSun Energy, LLC  
c/o Marie P. Barlow, OSB#144051  
390 SW Columbia St Ste 120  
Bend, OR 97702

By

- Mailing, by placing the copy in a postage prepaid sealed envelope addressed to the attorney's or other person's last known address as shown above and deposited with the U.S. Postal Service at Portland, OR by registered or certified mail.
- Commercial Delivery Service
- Facsimile
- Hand Delivery
- E-mail
- Electronic Service via the Appellate Courts' eFiling system at the email address as recorded on the date of service in the appellate eFiling system.

DATED this 29th day of January 2021.

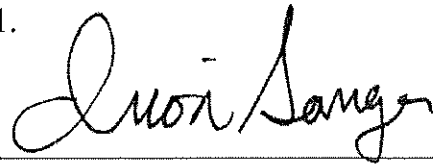
A handwritten signature in black ink, reading "Irion A. Sanger". The signature is written in a cursive style with a horizontal line underneath it.

Irion A. Sanger, OSB #003750  
Of Attorneys for Petitioners Renewable  
Energy Coalition, Northwest &  
Intermountain Power Producers Coalition,  
and Oregon Solar Energy Industries  
Association



**CERTIFICATE OF FILING**

I certify that I filed the foregoing **PETITION FOR JUDICIAL REVIEW** with the Appellate Court Administrator via the Oregon Appellate Court eFiling system and via mail to the address below:

Records Section  
Appellate Court Administrator  
Supreme Court Building  
1163 State Street  
Salem, OR 97301-2563

DATED this 29th day of January 2021.

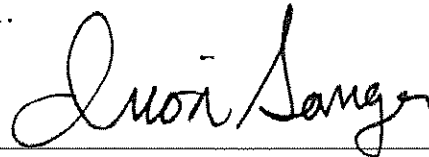

---

Irion A. Sanger, OSB #003750  
Of Attorneys for Petitioners Renewable  
Energy Coalition, Northwest &  
Intermountain Power Producers Coalition,  
and Oregon Solar Energy Industries  
Association

**ATTACHMENT A**

**OPUC DOCKET UM 2018 ORDER NO. 20-268**

**BEFORE THE PUBLIC UTILITY COMMISSION  
OF OREGON**

UM 2108

In the Matter of

PACIFICORP, dba PACIFIC POWER,

Application for an Order Approving Queue  
Reform Proposal.

ORDER

**DISPOSITION: STAFF'S RECOMMENDATION ADOPTED WITH  
MODIFICATIONS**

This order memorializes our decision, made and effective at our August 12, 2020 Special Public Meeting, to adopt PacifiCorp, dba Pacific Power's queue reform for Oregon-jurisdictional generators consistent with Staff's recommendations in the report attached as Appendix A, with the following modifications:

- Projects that executed a Facilities Study Agreement as of April 30 shall be treated as "late-stage projects" eligible to continue serial queue processing.
- Eligibility for the transition cluster shall be open to generators that entered the interconnection queue as of the date of the Special Public Meeting, August 12, 2020.
- Security deposit requirements for large generators shall be changed from PacifiCorp's proposed requirement of 100 percent of the project's share of estimated network upgrade costs at the time of an executed facilities study agreement to an amount consistent with Section 9.2 of the California Independent System Operator's Large Generator Interconnection Procedures. We understand that amount to be the lesser of the following three options:
  - 15 percent of the project's share of the estimated network upgrade costs at the time of an executed facilities study agreement;
  - \$20,000 per megawatt of the large generator's electrical output;
  - and
  - \$7,500,000.

Should Staff, in consultation with PacifiCorp and the parties, conclude that consistency with California's standards as listed above is unworkable or inappropriate, Staff may seek an expedited public meeting to discuss this issue.

- Generators are encouraged to submit their elections regarding participation in the Cluster Study process ahead of the September 15 deadline outlined

in Staff's recommendations, to the extent possible, in order to allow time for any necessary cure to such applications.

- No later than August 31, 2020, PacifiCorp shall file a document outlining expectations and the process for Oregon-jurisdictional small generators under PacifiCorp's Cluster Study process that is at least as clear as the rules regarding Oregon small generator interconnection, from which the waiver is granted. This document could consist of a redline of those rules, supplemented with information pertinent to the cluster study process, as set forth in PacifiCorp's application, to the extent approved. In this filing, PacifiCorp shall take care to address clearly its treatment of existing generators seeking to renew without material change and the process to request and expected contents of an Informational Interconnection Study. Staff will review this filing and elevate any issues associated with this filing to the Commission during a public meeting. Stakeholders may contact Staff regarding the content of the PacifiCorp filing.

Throughout the implementation of this significant change in interconnection procedure, we recognize that issues needing clarification or disputes needing resolution may arise. We encourage PacifiCorp to communicate clearly and proactively with interconnection customers to avoid disputes where possible. Staff may exercise its discretion to present any such issues to us through the UM 2111 interconnection process and policies investigation, or through the public meeting process.

We note that the decision windows for interconnection customers are relatively short throughout the study process and that this could create a QF contracting backlog, pressuring decisions to move forward in the cluster. In light of this, and to avoid facilities dropping out of a cluster, we strongly encourage PacifiCorp to work proactively and diligently with qualifying facilities participating in a cluster study to avoid this outcome. We will monitor and review implementation on an ongoing basis. As we move forward with the cluster approach, we preserve for later consideration the possibility of a concurrent serial approach. Similarly, we will monitor and address any cost-allocation issues that may arise in the course of implementation, including whether any costs that are sought to be allocated on a per capita basis, such as station upgrade costs, are appropriately allocated on that basis because they are caused by the existence of an interconnecting generator, irrespective of its size.

Made, entered, and effective Aug 20 2020.

*Megan W. Decker*

**Megan W. Decker**  
Chair

*Letha Tawney*

**Letha Tawney**  
Commissioner

*Mark R. Thompson*

**Mark R. Thompson**  
Commissioner



A party may request rehearing or reconsideration of this order under ORS 756.561. A request for rehearing or reconsideration must be filed with the Commission within 60 days of the date of service of this order. The request must comply with the requirements in OAR 860-001-0720. A copy of the request must also be served on each party to the proceedings as provided in OAR 860-001-0180(2). A party may appeal this order by filing a petition for review with the Circuit Court for Marion County in compliance with ORS 183.484.



UM 2108  
August 3, 2020  
Page 2

- Approve the proposed modifications to the Qualifying Facility Large Generator Interconnection Procedures and Qualifying Facility Large Generator Interconnection Agreement to implement a move from serial to cluster interconnection studies for all generators greater than 10 megawatts (MW);
- Approve the proposal to similarly move from serial to cluster interconnection studies for small generators subject to Tier 4 interconnection review under OAR 860-082-0060 and grant a waiver for good cause of the small generator interconnection rules set forth in OAR Chapter 860, Division 82 as necessary to implement cluster studies;
- Approve the proposed modifications to the Facilities Study Agreement for small generators subject to Tier 4 interconnection review;
- Approve the proposed process for transitioning from serial to cluster studies (Transition Process);
- Approve the proposed withdrawal penalties for large generators that withdraw during the interconnection study process; and
- Make the proposed reforms effective July 15, 2020.<sup>1</sup>

#### Applicable Rule or Law

OPUC has adopted rules and policies for how large and small Oregon-jurisdictional generators, i.e., Qualifying Facilities (QFs), interconnect under the Public Utility Regulatory Policies Act (PURPA) and Oregon law.

On September 8, 2009, the Commission adopted administrative rules for how QFs with a nameplate capacity of 10MW or less interconnect with utilities. OAR Division 82 of Chapter 860 Small Generator Interconnection Rules (OR-SGIP). OAR 860-082-0010 details the waiver requirements for the OR-SGIP. The Commission may grant a waiver of any of the Division 82 rules for good cause shown.

As part of the investigation into interconnection of PURPA Qualifying Facilities (QFs), the Commission issued Order No. 10-132 in Docket No. UM 1401, in which the Commission established standard large generator interconnection procedures (OR-LGIP) for generators 20 MW and larger and adopted a standard Large Generator Interconnection Agreement (OR-LGIA).

---

<sup>1</sup> See Docket No. UM 2108, PacifiCorp Application for an Order Approving Queue Reform Proposal, June 15, 2020 (hereinto referred to as "PAC Application").

UM 2108  
August 3, 2020  
Page 3

On January 31, 2020, the Company submitted proposed revisions to modify its FERC-jurisdictional Large Generator Interconnection Procedures (LGIP) and Small Generator Interconnection Procedures (SGIP), including the Large Generator Interconnection Agreement (LGIA) and Small Generator Interconnection Agreement (SGIA). On May 12, 2020, FERC accepted the Company's proposed revisions subject to conditions.

On June 15, 2020, the Company submitted proposed modifications to its OR-LGIP and OR-SGIP to align Oregon procedures with the FERC-jurisdictional reforms approved on May 12, 2020.

### Analysis

#### *Background*

In 2019, PAC initiated a queue reform process to overcome major issues preventing a functional generator interconnection process. As of February 2020, over 219 interconnection requests sat in its queue – equaling approximately 39,500 MW of generators awaiting interconnection.<sup>2</sup> The Company states that this volume is more than three times the amount of energy demand on the Company's system, demonstrating the impact of the backlog on generators system-wide.<sup>3</sup> In addition, roughly 14 percent of the total generators in PAC's queue are located in Oregon and less than one percent have indicated Oregon-jurisdictional interconnection (on a per MW basis).<sup>4</sup>

The Company attributes this backlog to processing interconnection requests in first come, first served serial queue order.<sup>5</sup> The cost and timing that is associated with each higher-queued request has an impact on the lower-queued request, resulting in a high volume of withdrawals from the queue.<sup>6</sup> Withdrawals often cause a restudy of projects that are lower in the queue because the study assumptions change when the project assumptions of higher-queued projects change, creating additional uncertainty for projects that have studies that assume the projects ahead of them would be online.<sup>7</sup> Having a high volume of serially processed interconnection requests has not only resulted in high costs and delayed timing for lower queued projects, but also has had a negative impact on the timing of study results. PAC initiated a stakeholder process to identify remedies to these conditions in 2019.

---

<sup>2</sup> PAC Application, p. 2.

<sup>3</sup> *Id.*

<sup>4</sup> Reflects PAC's OASIS Queue as of July 24, 2020, accessed here: <https://www.oasis.oati.com/ppw/>.

<sup>5</sup> *Id.*

<sup>6</sup> *Id.*

<sup>7</sup> *Id.* at 3.



UM 2108  
 August 3, 2020  
 Page 4

### FERC Queue Reform Process

After an informal stakeholder process in 2019, PAC submitted proposed revisions of its FERC LGIP and SGIP and the associated appendices to FERC on January 31, 2020.<sup>8</sup> The revisions included modifications to the Company's LGIA and SGIA in the Company's OATT. The FERC process involved several rounds of notices and responsive pleadings, with robust involvement from Oregon stakeholders.<sup>9</sup> The Renewable Energy Coalition (REC), the Community Renewable Energy Association (CREA), the Northwest and Intermountain Power Producers Association (NIPPC), Solar Energy Industries Association (SEIA), Renewable Northwest, and NewSun Energy (NewSun) all applied for, and were granted, intervener status in the FERC proceeding.<sup>10</sup> REC, CREA, Renewable Northwest, NewSun, and the Oregon Commission filed comments on the Company's filing with FERC.<sup>11</sup> Additionally, NewSun, CREA, SEIA, and NIPPC filed protests with the FERC proceeding.<sup>12</sup>

On March 6, 2020, FERC notified the Company that its filing was deficient and requested additional information.<sup>13</sup> The additional information included:

- Details of how the Company's revised interconnection procedures would comply with the requirements of PURPA;<sup>14</sup>
- How the Company plans to coordinate its upcoming and future Requests for Proposals with the timing of its interconnection process;<sup>15</sup>
- A description of what would constitute "comparable evidence" and "reasonable evidence" for the purpose of demonstrating readiness;<sup>16</sup>
- Clarification of whether interconnection customers would be able to be studied for both Energy Resource and Network Resource Interconnection service;<sup>17</sup>
- Explanation of how the Company was implementing Business Practice 73, and how that Business Practice would be implemented under the revised

<sup>8</sup> See generally FERC Docket No. ER20-924-000, PacifiCorp Tariff Filing, January 31, 2020.

<sup>9</sup> See FERC Docket No. ER20-924-000, Order No. 171 FERC ¶ 61,112 (May 12, 2020), *generally* and at 2.

<sup>10</sup> *Id.* at 2.

<sup>11</sup> *Id.* at 2.

<sup>12</sup> See FERC Docket No. ER20-924-000.

<sup>13</sup> See FERC Docket No. ER20-924-000, Deficiency Letter, Office of Energy Market Regulation (March 6, 2020).

<sup>14</sup> *Id.* at 1

<sup>15</sup> *Id.* at 2.

<sup>16</sup> *Id.*

<sup>17</sup> *Id.*

UM 2108  
 August 3, 2020  
 Page 5

interconnection procedures, including any limitations on availability of Network Resource Interconnection Service.<sup>18</sup>

The Company responded to the deficiency letter on March 13, 2020, along with responses to issues raised by commenters to the proceeding.<sup>19</sup> On April 12, 2020, FERC approved the Company's proposal and deficiency letter response, subject to conditions. The conditions included directing the Company to:

File an informational report with FERC within two years of the effective date of the order, including:

- An analysis of the commercial readiness criteria and whether improvements can, or should, be made to the revised process;<sup>20</sup>
- An analysis of whether the Company's reforms have improved study timelines for interconnection customers;<sup>21</sup>
- Information on withdrawals from the interconnection queue.<sup>22</sup>
- File a compliance filing within 45 days of the date of the order that includes revised provisions that:
  - Allow customers to be studied for both NRIS and ERIS in the initial Cluster Study.<sup>23</sup>
  - Expand the ability to demonstrate readiness by submitting a site-specific purchase order for generating equipment or a signed statement attesting that the facility will be supplied with generating equipment from only Load Serving Entities to all interconnection customers.<sup>24</sup>
  - Extend the Transition Readiness Deadline up to October 31, 2020, to provide flexibility to generators.

SEIA filed an expedited request for partial rehearing on May 15, 2020. CREA, SEIA, and NewSun filed requests for rehearing on June 11, 2020. The Company filed a response to these requests on June 26, 2020.<sup>25</sup> FERC issued an Order Granting

---

<sup>18</sup> *Id.* at 3.

<sup>19</sup> See FERC Docket No. ER20-924-000, PacifiCorp Response to Deficiency Letter and Request for Shortened Comment Period (March 13, 2020).

<sup>20</sup> <sup>20</sup> See FERC Docket No. ER20-924-000, Order No. 171 FERC ¶ 61,112 (May 12, 2020) at 17.

<sup>21</sup> *Id.*

<sup>22</sup> *Id.*

<sup>23</sup> *Id.* at 21.

<sup>24</sup> *Id.* at 30.

<sup>25</sup> See FERC Docket No. ER20-924-000, PacifiCorp Motion for Leave to Answer and Answer of PacifiCorp, June 26, 2020.

UM 2108  
August 3, 2020  
Page 6

Rehearing for Further Consideration on June 15, 2020.<sup>26</sup> However in absence of an order addressing the requests for rehearing on the merits, Staff believes the requests for rehearing may be deemed denied.<sup>27</sup>

#### Oregon Queue Reform Proposal

On June 15, 2020, the Company submitted an application for proposed modifications to its Oregon interconnection procedures to the Oregon Commission.<sup>28</sup> The purpose of this filing is to include Oregon-jurisdictional interconnection requests in PAC's first ready, first served Cluster Study process approved by FERC. Following the filing, the Company held a stakeholder workshop on June 24, 2020. Rather than move to comments as suggested by Staff, participants at the workshop requested additional discussion with PAC. As a result, PAC hosted two additional workshops. The first workshop, held on July 6, 2020, addressed the technical details of the Company's proposal.<sup>29</sup> The second workshop, held on July 7, 2020, addressed the relationship between the Company's proposal and the Company's PURPA implementation. After the workshops concluded, Staff proposed a docket scheduled to allow Stakeholders to submit written comments, and for the Company to apply to written comments in kind.<sup>30</sup>

NIPPC, CREA, Oregon Solar Energy Industries Association (OSEIA), NewSun, and REC filed comments on the Company's proposal (referred to collectively as "QF Parties").<sup>31</sup> Staff appreciates the Stakeholder engagement in the Company's filing, as well as the engagement in the FERC proceeding, to inform Staff's analysis. Stakeholder comments will be addressed in the analysis section of the memo.

The remainder of this report summarizes the changes that PAC proposes to make to the existing OR-LGIP and OR-SGIP, reviews the benefits and risks of moving Oregon generators to PAC's first ready, first served Cluster Process, and proposes modifications and conditions for approval of PAC's proposal.

---

<sup>26</sup> See FERC Docket No. ER20-924-000, Order Granting Rehearings for Further Consideration, Docket No. ER20-924-002 (June 15, 2020).

<sup>27</sup> *Allegheny Defense Project v. FERC*, No. 17-1098 (D.C. Cir. June 30, 2020).

<sup>28</sup> PAC Application.

<sup>29</sup> See Docket No. UM 2108, Notice of PacifiCorp's Oregon Queue Reform Workshops on July 6 and 7 (June 29, 2020).

<sup>30</sup> See Docket No. UM 2108, Staff's Notice of Next Steps (July 10, 2020).

<sup>31</sup> See Docket No. NIPPC's Comments, June 17, 2020; REC, CREA, and OSEIA's Joint Comments of the Interconnection Coalition, July 17, 2020 (hereinto referred to as "Joint Coalition Comments"); Joint Comments of NewSun Energy LLC and Oregon Solar Energy Industries Association (OSEIA), July 17, 2020, (hereinto referred to as "NewSun and OSEIA Comments").

UM 2108  
August 3, 2020  
Page 7

*Requested Changes to Oregon LGIP and SGIP*

Joining PAC's Cluster Study process requires several changes to Oregon's LGIP and SGIP. These changes are summarized below.

**Applicability.** PAC proposes to apply its FERC approved queue reforms to all Oregon-jurisdictional Large Generators (>10 MW – 80 MW) and Small Generators interconnecting under the Tier 4 process set forth in the OR-SGIP (25 kW – 10 MW).<sup>32,33</sup>

**Study Process.** Rather than studying each interconnection request sequentially in the order received, PAC's Cluster Process studies interconnection requests in clusters of geographically and/or electrically relevant generators (Cluster Areas).<sup>34</sup> The following are elements in PAC's Cluster Study Process that differ from existing Oregon Processes:

- Cluster System Impact Study (Cluster Study): A single Cluster System Impact Study will be performed for each Cluster Area. The Cluster Study considers all new generators in the Cluster Area with equal priority and allocates upgrades across generators through established criteria described further in this report.<sup>35</sup> PAC does not propose to modify the System Impact Study analysis, including the power flow, stability and short circuit analyses that are currently used.
- Annual Cluster Study Cycle: The Cluster Study process operates on a fixed annual cycle. The process includes a 45 day application window and requires increasing levels of commitment from generators after that. The increasing levels of commitment are on a fixed timeline, as well, to prevent delays and uncertainty for all cluster participants. PAC intends the annual process to allow sufficient time to finalize the outcome of the prior to launching the next.<sup>36</sup>
- Informational Interconnection Report: Generators may request Informational Interconnection Reports prior to submitting an Interconnection Application and committing to participate in the Cluster Study.<sup>37</sup> This study takes the

---

<sup>32</sup> PAC Application, p. 1.

<sup>33</sup> Tier 4 OR- SGIP interconnections are outlined in OAR 860-082-0060 and apply to Oregon jurisdictional generators 25 kW – 10 MW, that export power past the point of interconnection and do not pass the screening criteria for minimal system impacts under Tier 2 (OAR 860-082-0050).

<sup>34</sup> PAC Application, p. 25.

<sup>35</sup> *Id.*, at 25-26.

<sup>36</sup> *Id.* at 22.

<sup>37</sup> *Id.* at 35.

place of the Feasibility Study, which is currently provided after the generator applies for interconnection and is provided a place in the interconnection queue.

Other timelines and processes are modified to accommodate the annual cluster process as summarized in Figure 1 below and detailed in Attachment A.

Figure 1. Overview of Proposed Study Process Changes

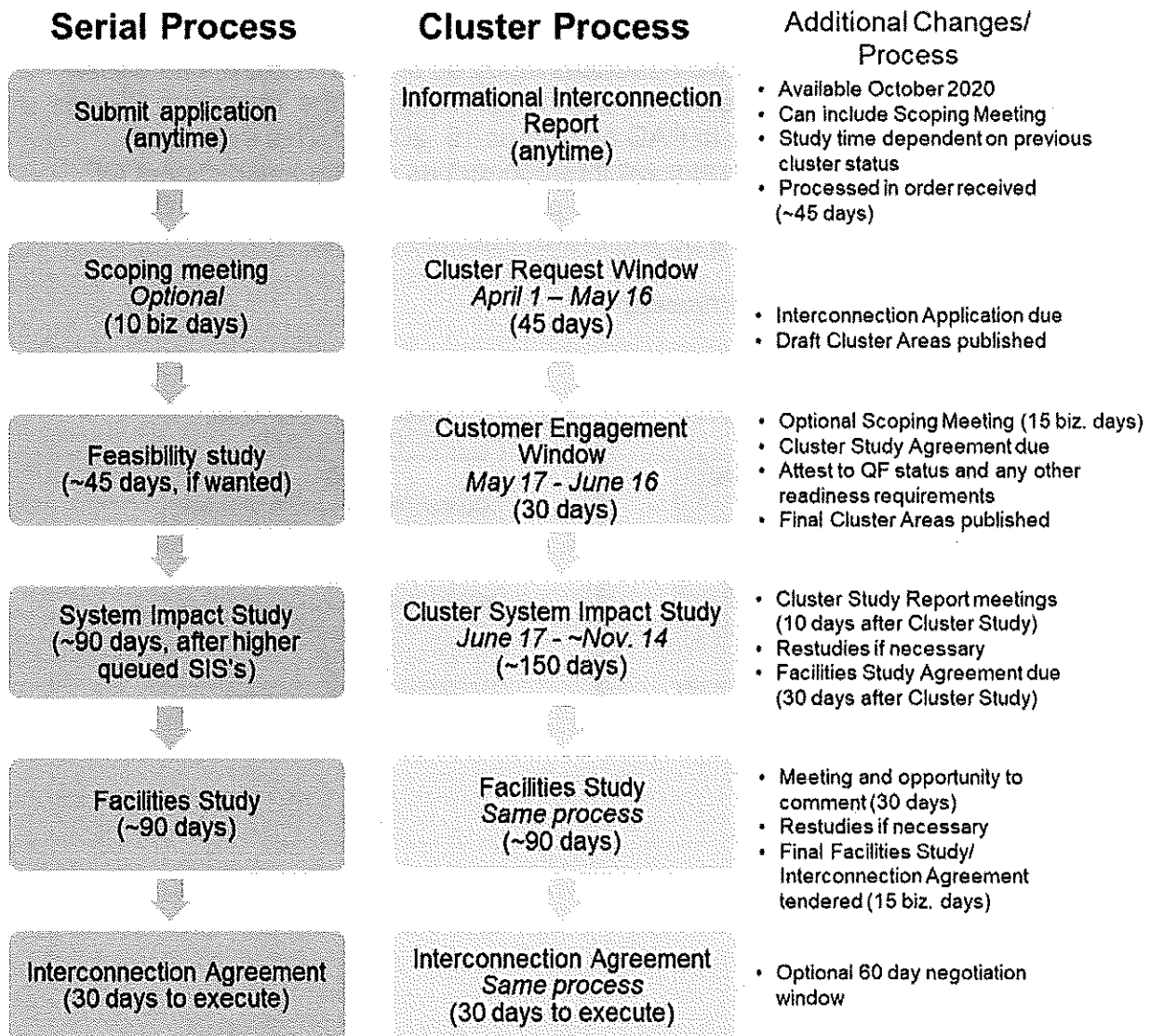

**Transition Process.** PAC proposes to conduct a Transitional Cluster Study Process before implementing what it describes as the “Prospective Cluster Study Process” that begins in April 1 of each year.<sup>38</sup> This transition process is intended to clear the backlog of non-commercially ready interconnection requests and align with the timing of PAC’s 2020 RFP.<sup>39</sup>

The Transitional Cluster Study will be restricted to active generators in the interconnection queue at the time that PAC filed for queue reform with FERC (January 31, 2020).<sup>40</sup> However, generators with an Interconnection Agreement executed prior to April 1, 2020, will proceed under that serial interconnection. Late stage projects that have a facilities study as of April 1, 2020, can chose either path.<sup>41</sup> Eligible projects that wish to participate in the Transition Cluster Study must provide notice to PAC by August 15, 2020.<sup>42</sup> This includes confirmation that the generator will interconnect as a state-jurisdictional QF. Eligible generators that do not elect to participate in the Transitional Cluster or do not remedy deficiencies will be withdrawn from the queue.

**Figure 2. Transition Cluster Process**<sup>43</sup>

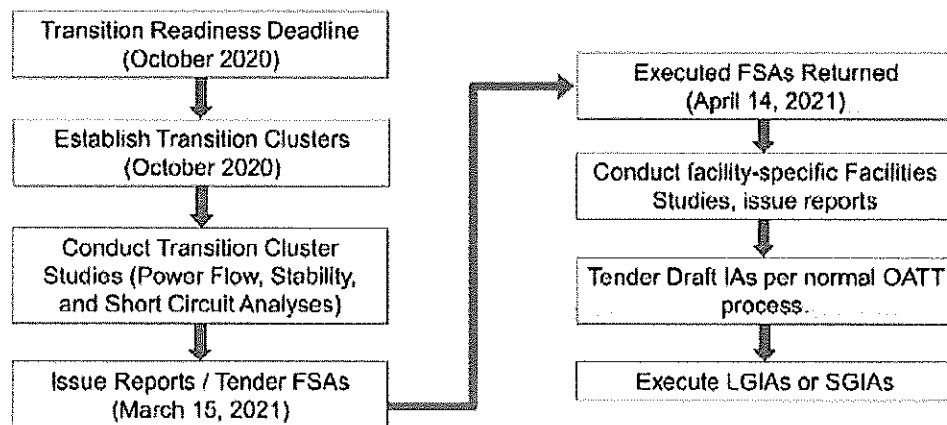

<sup>38</sup> *Id* at 6.

<sup>39</sup> *Id* at 15.

<sup>40</sup> *Id* at 6.

<sup>41</sup> Late-stage projects are those that have executed a Facilities Study Agreement by April 1, 18 2020. PAC Application, pp. 41-45.

<sup>42</sup> PAC Application, p. 41.

<sup>43</sup> *Id* at 43.

UM 2108  
August 3, 2020  
Page 10

**Cost Allocation.** In serial queue processing, the cost to perform each study and all interconnection upgrades triggered by that generator are borne by that single generator. Under queue reform, PAC proposes to assign the costs to perform the Cluster System Impact Study and the required upgrades through a combination of per capita and pro rata allocations based on MW size.<sup>44</sup> All other costs remain borne by solely by the generator, although withdrawal penalties will be used to cover certain restudy costs.

**Readiness Requirements and Withdrawal Penalties.** PAC's FERC queue reform proposal includes commercial readiness requirements to enter the queue, a different deposit structure, and increasing withdrawal penalties for generators exiting the queue after committing to participate in the Cluster Study. PAC proposes these modifications to increase certainty and facilitate efficient operation of the clusters. PAC's Oregon proposal does not modify the deposit requirements or impose withdrawal penalties on Oregon-jurisdictional Small Generators. However, Oregon Large Generators would be subject to a different deposit structure and withdrawal penalties that mirror the requirements for FERC-jurisdictional Large Generators.<sup>45</sup> Oregon-jurisdictional generators are currently required to demonstrate site control before entering the queue. PAC has not proposed to modify that requirement, but proposes a stricter definition of site control for Oregon Large Generators.<sup>46</sup>

#### *Oregon Interconnection Request Landscape*

Table 1 provides a snapshot of the landscape of existing or potential Oregon-jurisdictional interconnections in PAC's queue (generators that have or could elect to become Oregon QFs based on size and interconnection service type). These figures offer context for the scope of PAC's proposed queue reforms in Oregon. Ultimately, a small number of existing interconnection applicants in Oregon will be directly impacted by the Oregon Commission's decision. Detailed information about the Oregon generators in the table below is provided in Attachment B.

---

<sup>44</sup> *Id* at 20, 30.

<sup>45</sup> *Id* at 17-20.

<sup>46</sup> *Id* at 20-21.

UM 2108  
August 3, 2020  
Page 11

**Table 1. Approx. Landscape of Potential Oregon-Jurisdictional Generators<sup>47</sup>**

Type of Active Interconnection Application	Size <i>Large: &gt;10 - 80 MW</i> <i>Small: ≤10 MW</i>	Specify Oregon Jurisdiction		Specify FERC Jurisdiction		Total	
		#	MW	#	MW	#	MW
Eligible for Transition Queue <sup>48</sup>	Large <sup>49</sup>	-	-	17	1,179	17	1,179
	Small	17	42	-	-	17	42
Ineligible for Transition Cluster <sup>50</sup>	Large	1	80	4	100	5	180
	Small	-	-	-	-	-	-
<b>TOTAL</b>		18	122	21	1279	39	1,401

**Potential Oregon Generators:** Generators that interconnect under OR-LGIP and OR-SGIP are under 80 MW and have Network Resource Interconnection Status. There are 39 active generators in PAC's existing queue without an interconnection agreement that are able to do this, totaling roughly 1,400 MW. This is a relatively small number of generators when considering PAC's total queue of active interconnection requests exceeds 200 generators and 40,000 MW.<sup>51</sup> While 21 of these 39 potential Oregon generators currently plan to interconnect under the FERC process (91 percent on a MW basis), all of these generators could still elect to interconnect under the Oregon SGIP or LGIP.

**Generators 11 – 80 MW:** Over a GW of 11 MW – 80 MW Oregon generators are eligible for the Transition Cluster, representing roughly 3.5 percent of PAC's active interconnection requests on a MW basis. None of these generators have specified an intention to interconnect under the Oregon LGIP, but three quarters of these generators have left the door open by requesting Network Resource Interconnection Service (NRIS) or NR/ER Interconnection Service (13 out of 17).

**Generators ≤10 MW:** Adopting PAC's queue reform will immediately impact 17 existing generators 10 MW and under in Oregon, totaling 42 MW. In total, these Oregon-

<sup>47</sup> Reflects PAC's OASIS Queue as of July 24, 2020, accessed here: <https://www.oasis.oati.com/ppw/>.

<sup>48</sup> This includes generators specifying NR, ER and Oregon and FERC jurisdictional, as these generators have not been studied and can still notify PAC of an intent to interconnect as Oregon QFs. Staff also identified one Late-Stage Project that can proceed with its serial study results or participate in the Transition Cluster.

<sup>49</sup> Staff identified one Late-Stage Project that can proceed with its serial study results or participate in the Transition Cluster.

<sup>50</sup> Includes generators submitting interconnection requests after January 31, 2020.

<sup>51</sup> Reflects PAC's OASIS Queue as of July 24, 2020, accessed here: <https://www.oasis.oati.com/ppw/>.



UM 2108  
August 3, 2020  
Page 12

jurisdictional Small Generators represent one tenth of one percent of PAC's active interconnection requests on a MW basis.

Ineligible for Transition Cluster: Five large generators entered PAC's queue following the January 31, 2020, cut-off date (0.3 percent on a MW basis). Only one of these generators has specified an intention to interconnect under Oregon's procedures.

*Threshold Issue: Whether to include Oregon-jurisdictional interconnection requests in PAC's Cluster Study process*

The first ready, first served cluster process has already been approved by FERC and will occur under the timelines codified in the Company's OATT. Therefore, the heart of the decision before Oregon's Commission is whether to include Oregon generators in this process, including the 39 potential Oregon-jurisdictional generators currently in queue.

The following section reviews the implications, benefits, and risks of moving Oregon-jurisdictional generators to this process, rather than continuing to process Oregon-jurisdictional generators under the current serial LGIP and SGIP.

**Option 1: Move Oregon-jurisdictional generators to the first ready, first served cluster process.**

If the Commission decides to accept PAC's proposed queue reforms, Oregon-jurisdictional generators would be required to follow the FERC-approved interconnection process. First, existing Oregon-jurisdictional interconnection applicants would be held to the Transition Cluster Process and the associated timelines. Those not electing to participate in the Transition Cluster, or that cannot meet the requirements, will be withdrawn from the queue. Moving forward, applicable generators would be required to abide by the Prospective Cluster Process, including the annual study window, cost sharing provisions, and requirements for additional skin in the game.

**Option 2: Continue to process Oregon-jurisdictional generators under the existing first come, first served serial interconnection process.**

Prior to FERC's approval of PAC's queue reforms, PAC operated a single serial queue for interconnections under both FERC and Oregon procedures (large and small). If the Commission does not adopt PAC's queue reforms, PAC will process the majority of interconnection requests in clusters (FERC), with a small portion of interconnection requests serially within the same queue (Oregon).

UM 2108  
August 3, 2020  
Page 13

As PAC explains in its Reply Comments, interconnection studies rely on assumptions about which generators have already connected to the system.<sup>52</sup> These assumptions include generators that are planning to connect to the system<sup>53</sup> Cluster and serial studies cannot occur in parallel without using conflicting assumptions.<sup>54</sup> This means that PAC will need to position each annual cluster and each Oregon-jurisdictional interconnection in a serial order. Because the FERC Cluster Study dates are fixed, PAC will process serial Oregon-jurisdictional interconnections in between cluster studies.<sup>55</sup>

The first Prospective Cluster begins very soon after the Transition Cluster ends.<sup>56</sup> Therefore, PAC will not begin to process Oregon jurisdictional interconnections (in serial order) until the interval between the first and second Prospective Clusters. This interval is expected to no earlier than November 2021.

PAC asserts that restudies in the Cluster Process could limit the time available to process many serial studies PAC between clusters.<sup>57</sup> Staff finds that there is too much uncertainty surrounding the makeup of the Transition Cluster and subsequent Prospective Clusters to draw contrary conclusions about the time between clusters.

Regardless of whether Oregon participates in the cluster process, Oregon generators will benefit from PAC's efforts to clear its system-wide backlog and establish a more efficient queue through commercial readiness standards and withdrawal penalties. However, if Oregon does not participate, Staff has concerns about whether Oregon generators would be able to take advantage of the some of these benefits given PAC's obligation to follow the timelines in its FERC-approved OATT.

### **Benefits of adopting Queue Reform**

Staff finds that moving applicable Oregon-jurisdictional generators to the first ready, first served cluster process offers several benefits, as described below.

---

<sup>52</sup> See Docket No. 2108, PacifiCorp Reply Comments, July 24, 2020, p. 5, (hereinto referred to as "PAC Reply Comments").

<sup>53</sup> *Id.*

<sup>54</sup> *Id.*

<sup>55</sup> *Id.*

<sup>56</sup> *Id.* at 6.

<sup>57</sup> *Id.*

UM 2108  
 August 3, 2020  
 Page 14

*Benefit #1: Alignment across generator types*

PAC argues that aligning the Oregon interconnection procedures with the recently adopted FERC LGIP and SGIP will mitigate the risk of confusion and create practical efficiencies in the interconnection process.<sup>58</sup> Further, PAC cautions against maintaining an “Oregon-only queue” and states that a mismatch between policies could advantage Oregon QFs over Oregon generators participating in the 2020 Request for Proposals (RFP) and vice versa.<sup>59</sup>

The QF Parties argue that the stability of Oregon’s interconnection policies has benefitted generators with a long-term understanding of their rights and obligations and that PAC’s that there is no pressing need to align state and federal processes.<sup>60</sup>

However, the Oregon SGIP docket reflects that the parties that collaborated on draft rules intended to depart as little as possible from FERC SGIP and did so only when necessary to accommodate specific Oregon laws or rules.<sup>61</sup> Review of the LGIP order shows the Commission departed very minimally from the LGIP adopted by FERC. This history supports moving toward SGIP and LGIP adopted by FERC.<sup>62</sup>

Further, Staff finds that operating a serial queue and Cluster Study process in tandem will increase confusion, Oregon-jurisdictional study timelines, and disparity between the interconnection service different generators in the same queue receive.

*Benefit #2: Reduced interconnection costs through cost-sharing*

PAC’s queue reforms allow generators to share the cost of interconnection upgrades. PAC’s cost allocation policy includes the following:

- Station upgrades: Upgrades at the point of interconnection substation will be allocated on a per capita basis.<sup>63</sup> PAC explains that these station facilities are driven by the number of interconnecting generators, not the size of the interconnecting generators.<sup>64, 65</sup>

---

<sup>58</sup> PAC Application, pp. 47-49.

<sup>59</sup> *Id* at 48.

<sup>60</sup> Joint Coalition Comments, pp. 7, 10, NewSun and OSEIA Comments, pp. 1-5.

<sup>61</sup> See Docket No. AR 521.

<sup>62</sup> See Docket No. UM 1401.

<sup>63</sup> PAC Application, p. 30.

<sup>64</sup> PAC Reply Comments, p. 17.

<sup>65</sup> Station upgrades may include physical equipment such as circuit breakers, switches and instrument transformers along with their associated foundations, structures, bus and wire connections. The station upgrades also may include protective relays, shared communications infrastructure and other shared facilities such as fencing, ground grid, gravel, etc. See Attachment C.

UM 2108  
 August 3, 2020  
 Page 15

- Other upgrades: All other upgrades will be assigned on a pro rata basis first on the type of interconnection service requested (ERIS or NRIS) and thereafter on the proportional size of each generator (per MW).
- One percent floor: Generators that comprise 1 percent or less of the cluster on a MW basis will not be responsible for upgrade costs in that cluster (past the point of interconnection).<sup>66</sup>

The QF Parties argue PAC's station upgrade policy disadvantages smaller generators.<sup>67</sup> In comments, the QF Parties explain that it is unreasonable to assign equal shares of a \$25 million substation upgrade to a 3 MW and a 500 MW generator, for example.<sup>68</sup> This unfairness is exacerbated by the FERC generator's ability to receive reimbursement for the network upgrade costs.<sup>69</sup>

However, PAC notes that very small generators and very large generators will not interconnect to the same substations.<sup>70</sup> Further, the 1 percent floor is included to protect a generator under the circumstances that the QF Parties raise.

The QF Parties also recommend raising the 1 percent floor to 10 percent to reduce the cost burden on small generators. PAC explains that setting the floor as high as 10 percent introduces converse issues that could burden mid-size Oregon-jurisdictional generators.<sup>71</sup> For example, if a 200 MW Cluster Area includes two 50 MW generators and five 20 MW generators, each 20 MW generator will qualify for the 10 percent floor and force two similarly sized generators to bear 100 percent of the upgrade costs.

Staff shares the QF Parties' interest in protecting small generators from overly burdensome cost allocation, but finds that the potential disadvantages raised are not severe enough to reject a cost allocation that FERC has deemed reasonable to protect small generators. Particularly, they do not outweigh the burden that network upgrade costs already place on small Oregon-jurisdictional generators in the serial queue.<sup>72</sup>

---

<sup>66</sup> PAC Application, p. 30.

<sup>67</sup> Joint Coalition Comments, pp. 34 – 35.

<sup>68</sup> Joint Coalition Comments, p. 34.

<sup>69</sup> *Id.*

<sup>70</sup> PAC Reply Comments, p. 18.

<sup>71</sup> Joint Coalition Comments, pp. 38 - 39; NewSun and OSEIA Comments, p. 8.

<sup>72</sup> In the serial queue, generators can attempt to size under the threshold that will trigger an upgrade and secure the required queue position to take advantage of the head room. Generators can also attempt to rely on a higher queued generator to bear the full cost of an upgrade that is required for their interconnection, as well. Without these opportunities, Oregon QFs in the Cluster Study process may or may not be assigned costs that they would not have in serial order. However, Staff notes that relying on upgrades assigned to a single higher queued generator in serial order holds its own risks and contributed to the frustrations, uncertainty, and delays plaguing PAC's queue in recent years.

UM 2108  
August 3, 2020  
Page 16

As PAC implements the Cluster Studies, the appropriateness of PAC's station allocation methodology and 1 percent floor policies should be tracked in dockets such as UM 2111 and UM 2005. These dockets should consider the impacts of these policies and how these learnings fit into broader interconnection reform and system planning efforts.

Staff also acknowledges QF Parties' concerns that Oregon QFs are not reimbursed for network upgrades. These matters will be resolved in the context of UM 2032.

*Benefit #3: Improved planning and efficiency for generators*

Standardized study windows and the ability to study all requests simultaneously increase the certainty and speed of interconnection study timelines. This can help generators plan for other milestones, such as permitting and QF Power Purchase Agreements (PPAs). In addition, departing from the serial process removes the incentive for generators to seek queue priority for speculative projects to the harm of lowered queued generators that may be ready to commit to interconnection.

Clearing the queue through the Transition Cluster and increased skin in the game will also provide commercially ready generators with a more efficient process and higher likelihood of success. These changes to the FERC process will benefit Oregon QFs regardless of the Commission's decision in this docket. However, implementing the Transition Cluster and increased skin in the game for Oregon QF's will increase these benefits for all generators.

The QF Parties assert that new requirements in PAC's proposal could be burdensome and may deter interconnection. Of particular concern is limiting QF's freedom to choose when to act, including:

- Limiting the time in which a generator can request an interconnection study to once per year;<sup>73</sup>
- The 45-day window for submitting a request for interconnection, which does not necessarily provide generators enough time to fix any infirmities in the application before the Cluster Study window closes;<sup>74</sup>
- Limiting the generator's ability to downsize by 60 percent prior to executing a Cluster System Impact Study agreement;<sup>75</sup> and
- The 30-day window after the Cluster Study is finished in which generators must choose whether to proceed with interconnection and if proceeding, provide a deposit for upgrades, which is not sufficient opportunity for generators to provide

---

<sup>73</sup> Joint Coalition Comments, pp. 28-30; NewSun and OSEIA Comments, p. 7.

<sup>74</sup> Joint Coalition Comments, p. 40; NewSun and OSEIA Comments, p. 7.

<sup>75</sup> NewSun and OSEIA Comments, pp. 6-7.

UM 2108  
August 3, 2020  
Page 17

an independent study, assess the results, make a business decision on whether to move forward, and procure the necessary deposit for moving forward.<sup>76</sup>

PAC responds that, although the queue reforms will take away some of the generators' flexibility of when to apply for interconnection and when it can make modifications and withdraw, it will provide more certainty about when generators' interconnection studies will be complete.<sup>77</sup> Staff adds that, even if PAC continued to study Oregon generators' applications serially, PAC will be limited by the timing of cluster studies specified in its OATT.

Staff agrees with PAC that the current serial process can be unpredictable and subjects generators to the timing and decisions of higher queued projects. Although there is still the possibility of restudies and delays, there are also well established timelines for each annual Cluster Study process that generators can rely on. There are also multiple touchpoints in which generators can explore optionality, like changing the point of interconnection that do not harm other generators in the cluster.<sup>78</sup> Staff also notes that restudies in the FERC cluster will impact Oregon-jurisdictional generators regardless of participation in the cluster.

Staff appreciates the QF Parties' efforts to identify opportunities to improve PAC's OR-LGIP and OR-SGIP that are not directly related to queue reform. Examples include the additional opportunities to vet utility studies, utilizing third-party analyses, and making additional updates the OR-LGIP to reflect changes PAC has made to its FERC LGIP over the past decade. Staff looks forward to addressing these matters in UM 2111 and other related interconnection reform efforts.

Finally, QF Parties claim that queue reform is unnecessary and network upgrade constraints leading to interconnection issues are due to PAC's faulty power flow studies.<sup>79</sup> As mentioned previously, FERC's decision to adopt PAC's queue reform proposal is outside of the scope of this docket. The issue at hand is whether to move Oregon generators to this process.

#### *Staff Recommendation on Threshold Question*

Staff recommends that the Oregon Commission adopt PAC's proposal to align the OR-LGIP and OR-SGIP with the FERC first ready, first served cluster process. Staff finds that efficiency, certainty, and cost sharing benefits of PAC's

---

<sup>76</sup> *Id* at 7-8.

<sup>77</sup> PAC Reply Comments, pp. 15-17.

<sup>78</sup> For example, the scoping meeting during the customer engagement window.

<sup>79</sup> NewSun and OSEIA Comments, p. 4; NIPPC Comments, p. 4; Joint Comments, p. 7-9.

UM 2108  
August 3, 2020  
Page 18

proposal outweigh the generators' desire to apply for interconnection at any time or enter the interconnection process without a commercially ready project.

Nevertheless, Staff acknowledges that there are risks and implementation issues associated with PAC's proposal. The following section discusses these issues and provides recommendations to modify or add conditions to PAC's proposal, as necessary.

#### *Recommendations for implementation*

While Staff recommends moving Oregon QFs to the FERC Cluster Study, risks and other issues related to implementation warrant consideration. The following section outlines Staff and QF Parties' additional issues with the changes PAC proposes. Staff recommends modifications to PAC's proposal and additional conditions where applicable.

#### *Issue #1: Requirements for 10 – 20 MW generators*

QF Parties recommend that the Commission treat generators between 10 and 20 MW as small generators subject to the SGIP, rather than large generators subject to the LGIP.<sup>80</sup> PAC has exempted small generators from some of the requirements imposed on large generators in the queue reform proposal, and the QF Parties believe these exemptions should apply to generators up to 20 MW, as in FERC jurisdictional interconnections.

In Reply Comments, PAC disagrees that it is appropriate to apply to treat generators above 10 MW and up to 20 MW as small generators. PAC notes that the Commission's original framework was to treat generators greater than 10 MW as large generators.<sup>81</sup> PAC also notes that generators larger than 10 MW are almost always going to interconnect to the Company's transmission system and are if they withdraw are more likely to trigger a restudy. For these reasons, PAC asserts it is appropriate that the LGIP applies to generators greater than 10 MW and up to 20 MW.<sup>82</sup>

Staff response: Staff disagrees with PAC's reliance on the Commission's "original framework." The Staff Report asking the Commission to open an investigation into the interconnection of PURPA Qualifying Facilities with a nameplate capacity greater than 10 MW noted that stakeholders and utilities "supported the concept of using FERC's small generator interconnection procedures and agreements for

---

<sup>80</sup> Joint Coalition Comments, p. 52; NewSun and OSEIA Comments, p. 6.

<sup>81</sup> PAC Reply Comments, p. 35.

<sup>82</sup> *Id.*

UM 2108  
August 3, 2020  
Page 19

QFs between 10 MW and 20 MW, and FERC's large generator interconnection procedures and agreements for QFs over 20 MW."<sup>83</sup>

More importantly, PAC is implementing new queue reforms with uncertain impacts on Oregon-jurisdictional generators, and in a queue that is predominantly large FERC jurisdictional interconnections. It is reasonable and fair to align the OR-SGIP with the FERC rules.

Staff recommends modifying PAC's proposal to treat all Oregon QFs 20 MW as Small Generators.

*Issue #2: Tier 4 SGIP generators*

The QF Parties propose that Small Generators interconnecting under Tier 4 procedures should be exempt from the requirement to participate in the Cluster Study process.<sup>84</sup> They argue that Oregon Small Generators should have the same ability to proceed in a serial queue as CSP and net metering generators.<sup>85</sup> Further, the QF Parties argue that it is not reasonable to waive thoughtfully developed administrative rules for a single utility, and exempting Tier 4 Small Generators from queue reform would avoid the need to do so.<sup>86</sup>

PAC notes that Commission already addressed this issue when approving the separate CSP interconnection process.<sup>87</sup> Further, PAC points out that the CSP queue is for differently situated generators, and includes eligibility requirements to minimize system impacts and protections to ensure that only CSP generators participate.<sup>88</sup>

*Staff Response:* Staff agrees that the Commission has already established that CSP and net metering generators are differently situated than the Tier 4 Small Generators subject to PAC's queue reform proposal. Further, the CSP interconnection process consists of interim relief measures that the Commission required PAC to implement in the absence of broader queue reform.<sup>89</sup> As noted in the 6 month check-in, these CSP measures are effective in terms of producing timely studies, but have not yet demonstrated the ability to overcome the cost responsibility and uncertainty barriers associated with serial processing.<sup>90</sup>

---

<sup>83</sup> Docket No. UM 1401 Staff Report, QF Interconnection Investigation, p. 2 (October 29, 2008).

<sup>84</sup> Joint Coalition Comments, p.19.

<sup>85</sup> *Id* at 20.

<sup>86</sup> *Id* at 20.

<sup>87</sup> PAC Reply Comments, pp. 11-12.

<sup>88</sup> *Id*.

<sup>89</sup> See UM 1930, Staff Report for the October 22, 2019 Public Meeting.

<sup>90</sup> See UM 1930, Staff Report for the July 28, 2020 Public Meeting, pp. 6-13.



UM 2108  
 August 3, 2020  
 Page 20

*Issue #3: Transition Cluster eligibility and optionality*

The QF Parties claim that QFs were not provided sufficient notice of queue reforms and propose several adjustments to expand optionality for QFs:

- Allow new generators to request participation in the Transition Cluster for 30 days following Commission approval of PAC's queue reforms.
- Allow Oregon-jurisdictional generators with pending requests to proceed to serial study.
- Allow new requests made in 2020 to proceed with serial studies.<sup>91</sup>

PAC responds this first proposal is counter to the purpose of the Transition Cluster: clearing the backlog of existing interconnection requests.<sup>92</sup> In response to the second and third proposal, PAC explains that pending or new interconnection request entering the first Prospective Cluster would receive studies faster than the current serial timeframe.<sup>93</sup> Staff notes that participating in the first Prospective Cluster will return study results prior a serial studies performed between the first and second cluster, as well.

Staff response: The QF Parties' reforms will not help to clear the queue or provide more flexibility for QFs. Allowing serial processing will only restrict the serial studies to the time period between cluster studies. However, Staff recognizes that the August 15, 2020, timeline for generators to indicate participation in the Transition Cluster (as a QF) may be overly burdensome. Therefore, Staff recommends the following modifications to PAC's proposal:

- Give Oregon-jurisdictional generators a reasonable amount of additional time to indicate participation in the Transition Cluster. Staff proposes changing the deadline to September 15, 2020.
- Send a communication to all eligible Oregon-jurisdictional generators to ensure they are aware of the changes and the deadlines. Staff proposes sending the communication by August 20, 2020.

*Issue #4: Defining cluster areas*

QF Parties express concern that PAC has not clearly defined how Cluster Areas will be established.<sup>94</sup> In Reply Comments, PAC clarifies that it "cannot precisely define Cluster Study areas until the requests are submitted and the study participants are known," but,

<sup>91</sup> Joint Coalition Comments, p. 22.

<sup>92</sup> PAC Reply Comments, p. 23.

<sup>93</sup> *Id* at 23-24.

<sup>94</sup> Joint Coalition Comments, pp. 47-48.

UM 2108  
August 3, 2020  
Page 21

“PacifiCorp will define Cluster Study areas by discrete electrical boundaries (e.g. transmission line and substation interfaces).”<sup>95</sup>

Staff response: Staff agrees that additional clarity about Cluster Areas will benefit generators and help facilitate the first ready, first served approach. While PAC’s proposal includes a Draft Cluster Area report at the end of the Cluster Request Window and Final Cluster Area Report by the end of the Customer Engagement Window, Staff encourages to PAC to codify and continue to refine these criteria as much as possible for generators.

At minimum, Staff recommends that the Commission require PAC to submit a detailed description of its criteria for defining a Cluster Area in this docket and to file updates as this criteria evolves.

*Issue #5: Informational Interconnection Studies*

The QF Parties request that PAC process the Informational Interconnection Studies in the order received and use reasonable efforts to complete the studies in 45 days.<sup>96</sup> PAC agrees to these modifications.<sup>97</sup>

Staff response: Staff recommends that PAC update its revised OR-LGIP and OR-SGIP documents to clarify that it will process the Informational Interconnection Studies in the order receive and use reasonable efforts to complete the studies in 45 days.

*Issue #6: Burdensome readiness requirements*

The QF Parties assert that new readiness and withdrawal requirements could be burdensome and may deter interconnection.<sup>98</sup> The QF Parties also raised concerns about increased interconnection study costs.<sup>99</sup>

With respect to the heightened site control requirement, PAC explains that at the time of application a generator would be required to either demonstrate site control of a site of “sufficient size” as part of their interconnection request submission, or to provide a \$10,000 deposit in lieu of showing site control.<sup>100</sup> With respect to the subjectivity of the “sufficient size” requirement, PAC notes that it has posted the size requirements to

---

<sup>95</sup> PAC Reply Comments, p. 42.

<sup>96</sup> NewSun and OSEIA Comments, p. 8.

<sup>97</sup> PAC Reply Comments, p. 49.

<sup>98</sup> Joint Coalition Comments, pp. 24-25; NewSun and OSEIA Comments, pp. 7-8.

<sup>99</sup> Joint Coalition Comments, pp. 34-35; NewSun and OSEIA Comments, p. 7-8.

<sup>100</sup> PAC Reply Comments, pp. 32-33.

UM 2108  
 August 3, 2020  
 Page 22

OASIS.<sup>101</sup> To provide project developers with flexibility, PAC will also permit customers to propose alternative specifications for site size to those posted on OASIS.<sup>102</sup> PAC believes the site control requirement is important because Oregon Large Generators are not subject to the commercial readiness requirement applicable to FERC jurisdictional large generators.

PAC also disagrees that the withdrawal penalties should be reduced. PAC notes that these penalties only apply to large generators and only in certain circumstances. There are no penalties if the withdrawal does not negatively affect the timing or cost of other projects within the same cluster; the generator withdraws after receiving the most recent Cluster Study report and the costs assigned to the generator have increased by more than 25 percent compared to last Cluster Study report; or the generator withdraws after receiving the individual Facilities Study report and the costs assigned to the generator increase by more than 100 percent compared to the most recent Cluster Study.<sup>103</sup>

**Table 2. Withdrawal Penalties for Large Generators<sup>104</sup>**

<b>Point of Withdrawal</b>	<b>Withdrawal Penalty</b>	<b>Penalty Cap</b>
Receipt of Cluster Study Report	2x actual study costs	\$1 million
Receipt of Re-Study Reports	3x actual study costs	\$1.5 million
Receipt of Facilities Study Report	5x actual study costs	\$2 million
After LGIA Execution	9x actual study costs	No Cap

PAC disagrees with the QF Parties that the loss of study deposits is a sufficient deterrent to withdrawal and that penalties are unnecessary. PAC observes that this has not proven to be true in the past and that withdrawals and the need to restudy have presented significant challenges in the serial queue process.<sup>105</sup>

With respect to the requirement that Large Generators post security equal to 100 percent of the allocated network upgrade costs determined in the Cluster Study, PAC notes this requirement was relatively uncontroversial during the FERC proceeding and that there is no reason to treat large FERC jurisdictional generator differently than Oregon jurisdictional generators.<sup>106</sup> PAC also notes that its queue reform proposal does not change the types of security a generator may provide and that these remain as they are in the OR-LGIP.<sup>107</sup>

<sup>101</sup> *Id* at 32.

<sup>102</sup> *Id.*

<sup>103</sup> *Id* at 29.

<sup>104</sup> *Id* at 32.

<sup>105</sup> *Id* at 30.

<sup>106</sup> *Id* at 28.

<sup>107</sup> *Id.*

UM 2108  
August 3, 2020  
Page 23

With respect to the increased study costs, PAC notes the study costs would not increase for Oregon small generators.<sup>108</sup> The current LGIP requires a generator 20 MWs and above to pay a deposit of \$50,000 for a System Impact Study and \$100,000 for a Facilities Study. Under PAC's Queue Reform Proposal, a generator less than 50 MW would pay \$75,000, a generator between 50 MW and 250 MW would pay \$150,000. The only generators that will pay a higher study deposit under PAC's Queue Reform Proposal are generators larger than 200 MW, which are not subject to the Oregon Commission's jurisdiction.<sup>109</sup>

**Table 3. Proposed Deposit Changes**

<b>Generator Size</b>	<b>Current Deposit</b>	<b>Proposed Deposit</b>
>10 MW	Up to 50 percent of the estimated costs to perform the study or \$1000 <sup>110</sup>	Up to 50 percent of the estimated costs to perform the study or \$1000 <sup>111</sup>
>10 MW - 50 MW	\$10,000 – Feasibility Study <sup>112</sup> \$50,000 - System Impact Study <sup>113</sup> \$100,000 – Facilities Study <sup>114</sup>	\$75,000 <sup>115</sup>
>50 MW - 200 MW	\$10,000 – Feasibility Study <sup>116</sup> \$50,000 - System Impact Study <sup>117</sup> \$100,000 – Facilities Study <sup>118</sup>	\$150,000 <sup>119</sup>
200 MW or greater	N/A <sup>120</sup>	\$250,000 <sup>121</sup>

In terms of the allocation of study costs within a cluster, PAC will allocate 50 percent on a per capita basis and 50 percent on a pro rata basis (per MW). PAC argues that this approach strikes a reasonable balance because there are some study costs that are incurred regardless of how large a project may be, while others are driven by the size of the project studied. The QF Parties express concerns that small generators may bear an unreasonable level of cost, but PAC demonstrated that even in a cluster with just a

<sup>108</sup> *Id* at 22.

<sup>109</sup> *Id* at 30-31.

<sup>110</sup> OAR 860-082-0035.

<sup>111</sup> OAR 860-082-0035.

<sup>112</sup> PAC LGIP, Article 6.1.2.

<sup>113</sup> *Id* at Article 7.3.

<sup>114</sup> *Id* at Article 8.1.

<sup>115</sup> PAC Application, p. 19.

<sup>116</sup> PAC LGIP, Article 6.1.2.

<sup>117</sup> *Id* at Article 7.3.

<sup>118</sup> *Id* at Article 8.1.

<sup>119</sup> PAC Application, p. 19.

<sup>120</sup> OAR 860-029-0010(33).

<sup>121</sup> PAC Application, p. 19.

UM 2108  
August 3, 2020  
Page 24

very large (500 MW) and very small (3 MW) generator, the smaller generator would only bear about 26 percent of the study cost.

Staff response: Readiness requirements and withdrawal penalties are necessary in a first ready, first served cluster process. Staff does not disagree with FERC that these requirements for large generators strike a necessary balance, particularly considering Staff's recommendation to align the with FERC's definition of Small Generators up to 20 MW.

That said, these new requirements make it more important than ever for PAC to help generators anticipate upgrade costs and find suitable locations and project designs before the Cluster Request Window closes. In response to requests from the QF Parties, PAC proposed to post Informational Interconnection Studies publicly. Staff supports this and recommends the following set of conditions to limit the burden of readiness requirements and withdrawal penalties:

- Post Informational Interconnection Studies on OASIS.
- Accept interconnection applications at any point in the year for the next Cluster Study. Post the Interconnection Application data as its received, including location, point of interconnection, size, generator type, interconnection service, and applicable interconnection procedures.
- Work with Staff and Stakeholders to continue to refine the tools PAC makes available to help generators anticipate upgrade costs and find suitable locations and project designs before the Cluster Request Window closes.

*Issue #7: Interactions with the QF Power Purchase Agreement Process*

The QF Parties are concerned PAC's Proposal will eliminate generators' ability to time requests for PURPA power purchase agreements (PPAs) to take advantage of favorable avoided cost rates. The QF Parties assert that the Commission "allows frequent and unpredictable avoided cost price changes" by approving out-of-cycle avoided cost updates and rate changes repeatedly.<sup>122</sup>

The QF Parties note that PAC requires that a QF obtain a completed interconnection study before the QF can execute a PPA. If PAC's proposal is adopted, QF generators in may have to wait through multiple avoided cost price changes before they can obtain a

---

<sup>122</sup> NIPPC Comments, p. 26; NewSun and OSEIA Comments, pp. 5, 11; Joint Coalition Comments, pp. 24-33.

UM 2108  
August 3, 2020  
Page 25

legally enforceable obligation to sell to PAC.<sup>123</sup> QFs may not know their avoided cost rate until after the time that they are required to make commitments in the Cluster Study process that carry withdrawal penalties and impact other generators.<sup>124</sup> The QF Parties recommend that the Commission prevent PAC from requiring QFs to execute an interconnection agreement before securing a PPA.

Further, QF Parties express uncertainty about the impact of the Cluster Study on interconnection timelines and fear that they will fail to meet Commercial Operation Date (COD) requirement in the PPA for reasons beyond their control.<sup>125</sup> The QF Parties recommend that PAC grant QFs additional flexibility to terminate the PPA within 30 days of receiving the Cluster Study Report and modify the COD up to five years to correspond with the Cluster Study or Facilities Study.

PAC argues that its contracting procedures are outside of the scope and would more appropriately be addressed in AR 631. PAC asserts that the added certainty of the Cluster Study process will do more to help generators with these issues than harm.<sup>126</sup>

*Staff response:* Staff understands the QF Parties' concerns regarding the intersection of interconnection and PURPA implementation. However, Staff disagrees with the underlying premise that the current serial queue process is a preferable alternative to PAC's proposal. Staff believes the Cluster Study offers QF developers more certainty with respect to timing of the interconnection process than the current serial process. The Cluster Study process is far more likely to eliminate the log jam in PAC's interconnection queue and possibly, will allow QFs to mitigate their interconnection costs through sharing.

Staff also disagrees with the premise that a process in which a QF can obtain a PPA before knowing if it can afford to interconnect and when it can interconnect is superior to PAC's current process. Staff believes allowing QFs to enter into PPAs with no idea whether they will actually be able to interconnect necessarily results in speculative contracting. The Joint Coalition's proposal to allow QFs to enter into PPAs prior to obtaining an interconnection study and then let the QFs refresh their scheduled CODs to a later date to accommodate interconnection ignores the potential harm to ratepayers associated with stale avoided cost prices.

---

<sup>123</sup> Joint Coalition Comments, pp. 26-27; NewSun and OSEIA Comments, p. 11.

<sup>124</sup> Joint Coalition Comments, p. 24.

<sup>125</sup> *Id* at 31.

<sup>126</sup> PAC Reply Comments, p. 46.

UM 2108  
August 3, 2020  
Page 26

To the extent the QFs' concern with PAC's queue reform proposal relates to the uncertainty of avoided cost price changes, the timing of avoided cost price changes is within the Commission's control. Under the Commission's current process, avoided cost prices are updated on May 1 of each year, after IRP acknowledgement, and in out-of-cycle updates if certain criteria are satisfied. To the extent a QF believes an out-of-cycle update is inappropriate because of PAC's queue reform process, it can make that argument in opposition to the out-of-cycle update.

Furthermore, Staff agrees that the timing of the Transitional Cluster does not align with the May 1, 2021, avoided cost update. There is particular value in helping QFs make the most informed choice to commit to the Cluster Study process in this first time through. Therefore, Staff recommends that PAC move its May 1, 2021 avoided cost update to October 1, 2021.

*Issue #8: Time to Review Proposal*

NIPPC and the QFs recommend that the Commission take additional time to review the Proposal and conduct an investigation with workshops and opportunity for comment. The QFs propose that during the suspension and investigation, Oregon generators have the option to participate in the Transition Cluster Study, but otherwise, retain the ability to proceed in the serial interconnection queue without penalties for withdrawal of the interconnection application.<sup>127</sup> The Solar Advocates recommend a process for moving forward that includes two more workshops to (1) "work out specific changes which might facilitate stakeholder support and OPUC approval; and (2) address and form a pre-cluster study stakeholder process addressing the substantial-yet-basic power flow study issues identified by CREA's engineering support in its FERC filing.<sup>128</sup>

In response, PAC notes that its Oregon Proposal mirrors the Queue Reform Proposal adopted by FERC and that the reform efforts for the FERC proposal began over a year ago with a six-month stakeholder process that was well received and attended by numerous developers, including Oregon QF developers, trade associations, and Staff. PAC's proposal was then vetted at FERC, where it was reviewed by a wide range of interested stakeholders, including REC, CREA, NIPPC, and NewSun, who together filed over 150 pages of pleadings.<sup>129</sup>

**Staff response:** Staff understands the QF Parties' disappointment with the lack of opportunity to conduct a more robust stakeholder process for this docket. OPUC

---

<sup>127</sup> Joint Coalition Comments, p. 1.

<sup>128</sup> *Id.*

<sup>129</sup> PAC Reply Comments, p. 2.

UM 2108  
 August 3, 2020  
 Page 27

urged PAC to align its queue reform with the 2020 RFP, making this difficult timeline necessary to ensure that Oregon generators were not left behind. The Company has demonstrated that it is better for Oregon generators to join this process than allow Oregon generators to wait until November 2021 to begin seeing the benefits of queue reform.

*Issue #9: Implications for existing generators and points of uncertainty*

The QF Parties assert that there is a lack of clarity about how PAC's queue reform proposal interacts with current rules and policies. QFs state it is not clear whether:

- (1) A previously existing QF renewing an interconnection agreement must participate in a Cluster Study;
- (2) Previously paid interconnection study deposits will be applied toward a Cluster Study;
- (3) QFs will be given the opportunity to show that Network Upgrades for which it is responsible provide system benefits and that the costs should be shared with the Company;
- (4) QFs will be able to provide independent interconnection studies;
- (5) QFs will be able to obtain a PPA before receiving a Cluster Study report;
- (6) QFs will be able to correct errors on an interconnection application after the Cluster Study window closes;
- (7) QFs will be able to have more than one point of interconnection studied in a Cluster Study; or
- (8) QFs will be able to change point of interconnection during the study process.

More generally, all Stakeholders are concerned about the lack of clarity on which rules are waived and exactly what is intended to take their place.

PAC responds to the following issues as follows:

- (1) *Existing generators*: The SGIP are not changing except as specified in the queue reform proposal. With respect to existing generators, PAC confirms that its current and ongoing practice is that existing projects are not restudied in order to execute a new interconnection agreement unless there is a material change to the project, such as an increase in capacity. PAC further notes that the cluster process provides more certainty for the steps that the existing generators must take to renew its interconnection agreement prior to the expiration of its PPA.
- (2) *Previously paid deposits*: These will be applied toward the deposit for the Cluster Study.



UM 2108  
August 3, 2020  
Page 28

- (3) *QF opportunity to show Network Upgrades provide system benefits and should be allocated to all ratepayers:* This opportunity remains unchanged under queue reform proposal.
- (4) *QF opportunity to provide independent study.* The QF's ability to provide an independent study remains unchanged.
- (5) *Interconnection as condition of PPA requirement.* This requirement is unchanged except now the QF must have a completed Cluster Study rather than a "system interconnection study."
- (6) *Correcting errors on interconnection application after Cluster Study window:* PAC clarifies that because it is willing to accept applications for interconnection at any time, it is unnecessary to allow generators time after the Cluster Study window has closed to correct an application and that allowing this additional time could cause delays.<sup>130</sup>
- (7) *Multiple points of interconnection:* A customer cannot have multiple points of interconnection studied with one application in a Cluster Study. To the extent an interconnection customer wants to test various points of interconnection, they can use the Informational Interconnection Study.<sup>131</sup>
- (8) *Changing point of interconnection during study:* Generators will not be able to change the point of interconnection during the Cluster Study process because it increases the risk of restudies and undermines the certainty the Company is trying to achieve with Cluster Studies.<sup>132</sup>

Staff response: Staff finds PAC has addressed the points of uncertainty identified by stakeholders. Staff notes one point of uncertainty is due to a lack of clarity with the current SGIP. The SGIP are not entirely clear as to how a renewing generator with a material modification will be studied (i.e., is only the incremental change in capacity studied or the all of the generator's capacity?). PAC states that only the incremental capacity will be studied upon an application for renewal for or with a material modification.

Staff recommends that PAC file this clarification for existing generators in this docket.

---

<sup>130</sup> *Id* at 40.

<sup>131</sup> *Id* at 42-43.

<sup>132</sup> *Id.*

UM 2108  
August 3, 2020  
Page 29

*Issue #10: Ongoing reporting*

QF Parties recommend that PAC provide ongoing reporting on the status of implementing queue reforms.<sup>133</sup> PAC agreed to provide a detailed report on the implementation of queue reforms to FERC within two years.<sup>134</sup>

Staff response: Staff recommends that PAC's provide this report to the OPUC within two years.

*Summary of Staff Recommendations*

In this report, Staff recommends that the Commission adopt PAC's proposal to move Oregon-jurisdictional generators to PAC's Cluster Study process with modifications and additional conditions. The following section summarizes these recommendations.

Staff recommends that PAC submit a compliance filing before August 31, 2020, to implement the following modifications to its queue reform proposal:

- Treat Oregon-jurisdictional generators under 20 MW under the SGIP.
- Change the deadline to indicate participation in the Transition Cluster to September 15, 2020.
- Detail the criteria for defining a Cluster Area and update the Commission with a filing to this docket if the process or criteria are refined over time.
- Clarify that PAC will process the Informational Interconnection Studies in the order received and use reasonable efforts to complete the studies in 45 days.
- Accept interconnection applications at any point in the year, post the Interconnection Application data as received, including location, point of interconnection, size, generator type, interconnection service, and applicable interconnection procedures.
- Clarify the policy and process for existing generators.

Staff recommends that the Commission require PAC to adhere to the following additional conditions:

- Send a communication to all eligible Oregon QFs to ensure they are aware of the changes and the deadlines. Staff proposes sending the communication by August 20, 2020.

---

<sup>133</sup> NewSun and OSEIA Comments pp. 11-12.

<sup>134</sup> PAC Reply Comments, pp. 39-40.

UM 2108  
August 3, 2020  
Page 30

- Post Informational Interconnection Studies on OASIS.
- Work with Staff and Stakeholders to continue to refine the tools PAC makes available to help generators anticipate upgrade costs and find suitable locations and project designs before the Cluster Request Window closes.
- Move PAC's May 1, 2021 avoided cost update to October 1, 2021.
- Provide a report on the status of implementing queue reform within two years.

### Conclusion

On May 12, 2020, FERC approved PAC's request to modify its Open Access Transmission Tariff for the purpose of interconnection queue reform. This proposal moves FERC-jurisdictional interconnection requests from a first come, first served serial process to a first ready, first served Cluster Study process. Following FERC approval, the Company requests approval to include Oregon-jurisdictional interconnections in the first ready, first served cluster process. Specifically, PAC requested that OPUC approve the following:

- Approve the proposed modifications to the Qualifying Facility Large Generator Interconnection Procedures and Qualifying Facility Large Generator Interconnection Agreement to implement a move from serial to cluster interconnection studies for all generators greater than 10 megawatts (MW);
- Approve the proposal to similarly move from serial to cluster interconnection studies for small generators subject to Tier 4 interconnection review under OAR 860-082-0060 and grant a waiver for good cause of the small generator interconnection rules set forth in OAR Chapter 860, Division 82 as necessary to implement cluster studies;
- Approve the proposed modifications to the Facilities Study Agreement for small generators subject to Tier 4 interconnection review;
- Approve the proposed process for transitioning from serial to cluster studies (Transition Process);
- Approve the proposed withdrawal penalties for large generators that withdraw during the interconnection study process; and
- Make the proposed reforms effective July 15, 2020.<sup>135</sup>

---

<sup>135</sup> See Docket No. UM 2108, PacifiCorp Application for an Order Approving Queue Reform Proposal, June 15, 2020 (hereinto referred to as "PAC Application").

UM 2108  
August 3, 2020  
Page 31

Staff reviewed the proposal with Stakeholder through three workshops, followed by a round of Stakeholder Comments and Reply Comments from PAC.

Staff recommends that the Commission adopt PAC's proposal to move Oregon-jurisdictional generators to PAC's Cluster Study process with modifications and additional conditions. Staff recommends that PAC submit a compliance filing before August 31, 2020, to implement these modifications.

**PROPOSED COMMISSION MOTION:**

Approve PAC's request for approval of queue reform proposal, with modifications and conditions.

UM 2108 PAC Queue Reform

UM 2108  
August 3, 2020  
Page 32

### Attachment A – Cluster Study Process

PAC will conduct the Cluster Studies annually, following this process, which was approved by FERC:

1. Informational Interconnection Study (any time). Rather than provide a Facilities Study following the submission of an interconnection request, PAC will provide the Informational Interconnection Study with the same information as the Facilities Study at any time prior to submission of an interconnection request.<sup>136</sup> This balances the heightened readiness and “skin in the game” practices.
2. Cluster Study Request Window (45 days): Rather than take applications at any time, PAC will accept interconnection requests during an annual 45 calendar day window, from April 1 – May 16.<sup>137</sup> After the window closes, PAC will post a draft Cluster Study plan to its Open Access Same-time Information System (OASIS) site.<sup>138</sup> The plan lists and maps the generators in each Cluster Area.<sup>139</sup>
3. Customer Engagement Window (30 days): PAC will conduct Scoping Meetings with generators that applied for interconnection during the 30 calendar day the Cluster Study Request Window. Generators must return an executed Cluster System Impact Study Agreement to PAC by the end of the Cluster Study Window. PAC will post a final Cluster Study plan on OASIS by no later than the end of the Customer Engagement Window, as well.<sup>140</sup>
  - NOTE: Generators may not receive a Cluster Study Agreement until five business days into the Customer Engagement Window.<sup>141</sup>
4. Cluster System Impact Study (~150 days): PAC will perform one Cluster System Impact Study (Cluster Study) per Cluster Area which includes a non-binding estimate of each generators’ share of the upgrade costs.<sup>142, 143</sup> PAC will make reasonable efforts to complete the cluster studies in 150 calendar days of the close of the Customer Engagement Window. Upon receiving the Cluster Study Report, generators have 30 calendar days to determine whether to proceed to a Facilities Study or withdraw from the interconnection process. PAC will post Cluster Studies to OASIS.<sup>144</sup>

---

<sup>136</sup> PAC Application, p. 35.

<sup>137</sup> PAC Application, pp. 21-22.

<sup>138</sup> PAC Application, p. 23.

<sup>139</sup> PAC Application, p. 23.

<sup>140</sup> PAC Application, p. 24.

<sup>141</sup> PAC Proposed LGIP, Article 7.1.

<sup>142</sup> PAC Application, p. 25.

<sup>143</sup> PAC is not proposing to modify the analyses currently required for a System Impact Study, such as short circuit, stability, power flow. See LGIP Article 7.3 and OAR 860-082-0060(7)(g).

<sup>144</sup> PAC Application, p. 26.

UM 2108  
August 3, 2020  
Page 33

- Restudy: If generators withdraw, PAC may restudy the Cluster Area.<sup>145</sup> Restudies will reset the Cluster Study timelines and may impact the upgrades allocated to remaining generators.<sup>146</sup> PAC will electronically notify generators in the Cluster and post on OASIS that a restudy is required.
5. Facilities Study (~90 days): PAC will perform a separate Facilities Study for each generator based on the findings in the Cluster Study.<sup>147</sup> PAC will follow the current Facilities Study process, which include: attempt to issue a draft Facilities Study Report within 90 calendar days of the Facilities Study Agreement;<sup>148</sup> meet with the generator to discuss; the generator will have 30 calendar days to provide comments. Following any comments, PAC will return a final Facilities Study within 15 business days.
- Restudy: PAC will attempt to conduct Facilities Study restudies in 60 calendar days.<sup>149</sup>
6. Interconnection Agreement (30 days): The Facilities Study is followed by the current negotiation and interconnection agreement procedures: The generator has 30 calendar days to return the executed Interconnection Agreement, but can take 60 calendar days to negotiate with the utility prior to the 30 days.<sup>150</sup>

---

<sup>145</sup> PAC Application, p. 27.

<sup>146</sup> PAC Application, pp. 27-28.

<sup>147</sup> Proposed QF-LGIP Article 8.

<sup>148</sup> PAC Application, p. 28.

<sup>149</sup> PAC Application, o. 29.

<sup>150</sup> Proposed QF-LGIP, p. Article 11.

UM 2108  
August 3, 2020  
Page 34

### Attachment B– Existing OR Interconnection Queue

Below is Staff’s best effort to capture potential Oregon-jurisdictional generators in PAC’s interconnection queue. This data is as of July 24, 2020. Interconnection queue data and dynamic and generators are able to modify certain aspects of their interconnection request in addition to status and milestones. For example move for NR/ER interconnection service to NR or ER in order to execute and interconnection agreement.

#### Eligible for the Transitional Cluster

Under PAC’s proposal, the following generators are eligible to participate in the Transition Cluster. Other than late-stage generators, these generators must participate in the Transition Cluster or withdraw from the interconnection queue. Because these generators have not been studied and will not affect lower queued generators by changing service type, Staff includes all generators located in Oregon, 80 MW and under in the pool of potential QFs.

NOTE: Oregon QFs that have executed a Facilities Study Agreement by April 1, 2020, (late-stage generators) can also choose to proceed according to the terms of their serial study. Staff identified one of these generators in PAC’s queue: Large Generator Q# 739.

Q#	Request Date	Service Type	Specified OR Jurisdictional	Size (MW)	County	ST	Type
LARGE GENERATORS – 80 MW and under, located in OR, no Facilities Study prior to April 2020							
739	4/29/2016	ER	**late stage	59	Crook	OR	Solar
905	7/12/2017	NR		50	Klamath	OR	Solar
915	7/28/2017	ER		80	Klamath	OR	Solar & Battery Storage
916	7/28/2017	ER		80	Klamath	OR	Solar & Battery Storage
917	7/28/2017	ER		80	Klamath	OR	Solar & Battery Storage
1031	5/30/2018	NR/ER		80	Harney	OR	Solar & Battery Storage
1032	5/30/2018	NR/ER		80	Harney	OR	Solar & Battery Storage
1033	5/30/2018	NR/ER		80	Harney	OR	Solar & Battery Storage
1034	6/5/2018	NR/ER		60	Lake	OR	Solar
1087	11/26/2018	NR/ER		50	Lake	OR	Solar & Battery Storage
1133	5/7/2019	NR/ER		80	Klamath	OR	Solar & Battery Storage
1135	5/7/2019	NR/ER		80	Klamath	OR	Solar & Battery Storage
1161	9/19/2019	NR/ER		40	Crook	OR	Solar & Battery Storage
1162	9/19/2019	NR/ER		80	Crook	OR	Solar & Battery Storage
1163	9/19/2019	NR/ER		40	Crook	OR	Solar & Battery Storage

UM 2108  
August 3, 2020  
Page 35

1164	9/19/2019	NR/ER		80	Crook	OR	Solar & Battery Storage
1188	11/1/2019	NR/ER		80	Crook	OR	Solar & Battery Storage
			<b>COUNT</b>	<b>17</b>			
			<b>TOTAL MW</b>	<b>1179</b>			
<b>SMALL GENERATORS – 10 MW and under, located in OR, no Facilities Study prior to April 2020</b>							
1043	6/26/2018	ER	X	3	Klamath	OR	Solar
1045	7/5/2018	NR	X	3	Umatilla	OR	Solar
1058	8/14/2018	ER	X	3	Klamath	OR	Solar
1059	8/14/2018	ER	X	3	Klamath	OR	Solar
1097	1/9/2019	NR	X	3	Polk	OR	Solar
1098	1/9/2019	NR	X	3	Polk	OR	Solar
1099	1/9/2019	ER	X	3	Jackson	OR	Solar
1104	1/16/2019	NR	X	3	Josephine	OR	Solar
1105	1/31/2019	ER	X	3	Klamath	OR	Solar
1120	3/11/2019	NR	X	3	Jackson	OR	Solar
1124	4/8/2019	NR	X	0	Deschutes	OR	Solar
1125	4/8/2019	NR	X	0	Deschutes	OR	Solar
1126	4/8/2019	NR	X	8	Klamath	OR	Geothermal
1147	6/25/2019	NR	X	3	Jackson	OR	Solar
1149	7/11/2019	ER	X	0	Benton	OR	Solar
1150	7/11/2019	ER	X	1	Benton	OR	Solar
1151	7/11/2019	ER	X	0	Benton	OR	Solar
			<b>COUNT</b>	<b>17</b>			
			<b>TOTAL MW</b>	<b>42</b>			

### Ineligible for the Transition Cluster

Under PAC's proposal, the following generators are ineligible to participate in the Transition Cluster. These generators can participate in the first Prospective Cluster in April 2021 if they meet the commercial readiness and other requirements.

Q#	Request Date	Service Type	Specified OR Jurisdictional	Size (MW)	County	ST	Type
<b>LARGE GENERATORS – 80 MW and under, located in OR, entered queue after Jan. 31, 2020</b>							
1204	4/6/2020	NR	SGI	20	Crook	OR	Solar
1205	4/6/2020	NR	SGI	20	Crook	OR	Solar
1206	4/6/2020	NR	SGI	20	Crook	OR	Solar
1214	4/13/2020	NR/ER	LGI	40	Crook	OR	Solar & Battery Storage



UM 2108  
 August 3, 2020  
 Page 36

1219	4/20/2020	NR	OLGI	80	Umatilla	OR	Solar & Battery Storage
			<b>COUNT</b>	<b>5</b>			
			<b>TOTAL MW</b>	<b>180</b>			
SMALL GENERATORS – 10 MW and under, located in OR, entered queue after Jan. 31, 2020							
<b>None</b>							

UM 2108  
August 3, 2020  
Page 37

## Attachment C – PAC Explanation of Station Upgrades

UM 2108 / PacifiCorp  
July 24, 2020  
OPUC Information Request 2

### OPUC Information Request 2

Please explain why PacifiCorp chose to allocate station upgrades on a per capita basis.

- Please list the upgrades that will be considered a station upgrades and explain why each upgrade will be the same per project, regardless of project size.
- Please include whether the upgrade is anticipated to occur at the distribution or transmission substation level or both.
- Please explanation how communications upgrades, such as running fiber to the substation, will be allocated and if it differs between the distribution and transmission level.

### Response to OPUC Information Request 2

- Station upgrades include all network upgrades at the point of interconnection substation, which may include physical equipment such as circuit breakers, switches and instrument transformers along with their associated foundations, structures, bus and wire connections. The station upgrades also may include protective relays, shared communications infrastructure and other shared facilities such as fencing, ground grid, gravel, etc.

These station facilities are designed and constructed on a per-termination basis and the specifications for equipment is determined by the voltage class and system characteristics on a whole station basis, not by the anticipated power flow of any one termination. For this reason, cost allocation on a per capita basis instead of pro rata size basis is appropriate.

As an example, the number of positions for a new 115 kV point of interconnection (POI) substation looping through an existing transmission line would be determined as follows:

**Example 1:** One interconnection at POI: three total bus positions arranged in a ring configuration with three circuit breakers separating the two networked transmission lines and the one generation interconnection line.

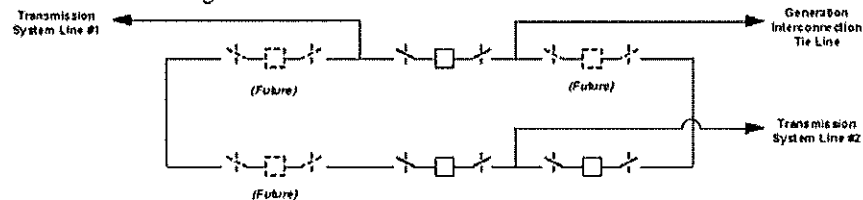

Despite PacifiCorp's diligent efforts, certain information protected from disclosure by the attorney-client privilege or other applicable privileges or law may have been included in its responses to these data requests. PacifiCorp did not intend to waive any applicable privileges or rights by the inadvertent disclosure of protected information, and PacifiCorp reserves its right to request the return or destruction of any privileged or protected materials that may have been inadvertently disclosed. Please inform PacifiCorp immediately if you become aware of any inadvertently disclosed information.

UM 2108 / PacifiCorp  
 July 24, 2020  
 OPUC Information Request 2

**Example 2:** Two interconnections at POI; four total bus positions arranged in a ring configuration with four circuit breakers separating the two networked transmission lines and the two generation interconnection lines.

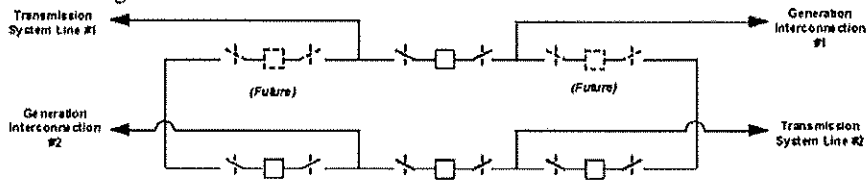

Transmission substations with six or greater line terminations generally have 1.5 circuit breakers assigned per line position due to the redundancy and operability benefits associated with a standard "breaker and a half" configuration.

**Example 3:** Four interconnections at POI; six total bus positions arranged in a breaker-and-a-half configuration with nine circuit breakers separating the two networked transmission lines and the four generation interconnection lines.

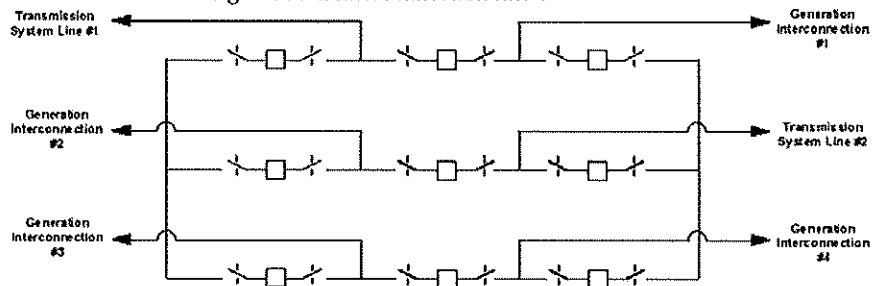

Transmission voltage bus configurations are designed to maintain compliance with NERC reliability standards and system operating requirements, presenting different design criteria than distribution voltage bus configurations. For distribution voltage buses with radial feeders, a more standard bus configuration is a main and transfer arrangement with a single circuit breaker per feeder position.

**Example 4:** New generation interconnection with a POI at an existing distribution substation distribution bus, resulting in addition of a new circuit breaker position:

Despite PacifiCorp's diligent efforts, certain information protected from disclosure by the attorney-client privilege or other applicable privileges of law may have been included in its responses to these data requests. PacifiCorp did not intend to waive any applicable privileges or rights by the inadvertent disclosure of protected information, and PacifiCorp reserves its right to request the return or destruction of any privileged or protected materials that may have been inadvertently disclosed. Please inform PacifiCorp immediately if you become aware of any inadvertently disclosed information.

UM 2108  
August 3, 2020  
Page 39

UM 2108 / PacifiCorp  
July 24, 2020  
OPUC Information Request 2

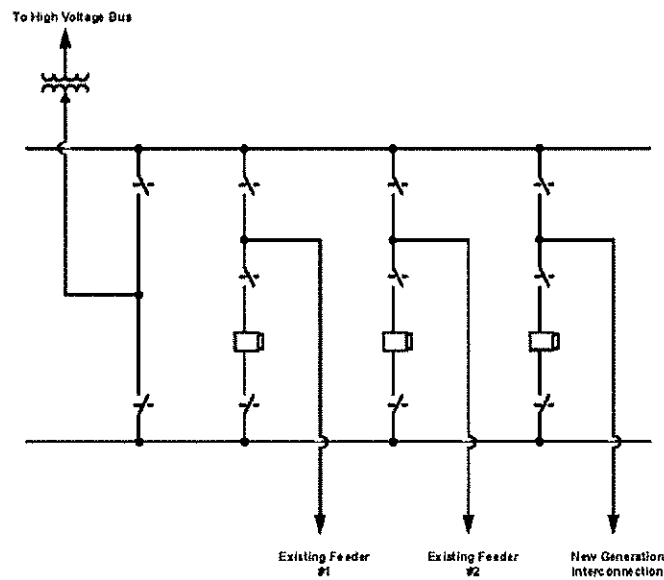

- b. Upgrades may occur at both the transmission and distribution levels depending on the specifics of the interconnection request and factors such as the existing system topology, existing and requested generation nearby, system load and other characteristics of the requested point of interconnection and interconnected system. Interconnection studies will identify any and all system upgrades required to maintain a safe and reliable system, regardless of the voltage of the requested interconnection or the voltage of the impacted system facilities.
- c. Communications equipment will be allocated on a per capita basis along with other station equipment. The communications requirements are determined by the protection systems used (e.g. data transmission, transfer trip, remedial action schemes, etc.) and are not directly associated with the transmission or distribution voltage of interconnection.

Despite PacifiCorp's diligent efforts, certain information protected from disclosure by the attorney-client privilege or other applicable privileges of law may have been included in its responses to these data requests. PacifiCorp did not intend to waive any applicable privileges or rights by the inadvertent disclosure of protected information, and PacifiCorp reserves its right to request the return or destruction of any privileged or protected materials that may have been inadvertently disclosed. Please inform PacifiCorp immediately if you become aware of any inadvertently disclosed information.

**ATTACHMENT B**

**OPUC DOCKET UM 2018 ORDER NO. 20-465**

ORDER NO. 20-465

ENTERED Dec 04 2020

**BEFORE THE PUBLIC UTILITY COMMISSION  
OF OREGON**

UM 2108

In the Matter of

PACIFICORP, dba PACIFIC POWER

Application for Rehearing or Reconsideration  
of Community Renewable Energy  
Association, Oregon Solar Energy Industries  
Association, and NewSun Energy LLC; and

Application for Rehearing or Reconsideration  
of the Renewable Energy Coalition, Oregon  
Solar Energy Industries Association, and  
Northwest and Intermountain Power  
Producers Coalition.

ORDER

**DISPOSITION: STAFF'S RECOMMENDATION ADOPTED WITH MODIFICATION**

This order memorializes our decision, made and effective at our December 1, 2020 Regular Public Meeting, to adopt Staff's recommendation with a modification in this matter. We waive the current requirement for Oregon Large Generators to post a financial security deposit for Network Upgrades until 45 days following the receipt of the Cluster System Impact Study.

The Staff Report with the recommendation is attached as Appendix A.

Made, entered, and effective Dec 04 2020.



**Megan W. Decker**  
Chair

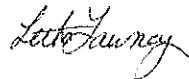

**Letha Tawney**  
Commissioner

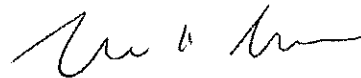

**Mark R. Thompson**  
Commissioner



A party may request rehearing or reconsideration of this order under ORS 756.561. A request for rehearing or reconsideration must be filed with the Commission within 60 days of the date of service of this order. The request must comply with the requirements in OAR 860-001-0720. A copy of the request must also be served on each party to the proceedings as provided in OAR 860-001-0180(2). A party may appeal this order by filing a petition for review with the Circuit Court for Marion County in compliance with ORS 183.484.

**PUBLIC UTILITY COMMISSION OF OREGON  
STAFF REPORT  
PUBLIC MEETING DATE: December 1, 2020**

**REGULAR**  X  **CONSENT**       **EFFECTIVE DATE**  December 1, 2020

**DATE:** November 23, 2020

**TO:** Public Utility Commission

**FROM:** Stephanie Andrus and Caroline Moore

**THROUGH:** Bryan Conway and JP Batmale **SIGNED**

**SUBJECT:** PACIFIC POWER:  
(Docket No. UM 2108)  
Application for Rehearing or Reconsideration of Community Renewable Energy Association, Oregon Solar Energy Industries Association, and NewSun Energy LLC.

Application for Rehearing or Reconsideration of the Renewable Energy Coalition, Oregon Solar Energy Industries Association, and Northwest and Intermountain Power Producers Coalition.

**STAFF RECOMMENDATION:**

Grant the Application for reconsideration filed by Community Renewable Energy Association, Oregon Solar Industries Association, and Northwest and Intermountain Power Producers Coalition with respect to the network upgrade security deposit requirement for the Transition Cluster Study as proposed by Staff and otherwise deny the request for reconsideration or rehearing.

Deny the Application for rehearing or reconsideration filed by the Renewable Energy Coalition, Oregon Solar Energy Industries Association, and Northwest and Intermountain Power Producers Coalition.

**DISCUSSION:**

Issue

Whether the Oregon Public Utility Commission (Commission) should approve applications for reconsideration or rehearing of its order approving PacifiCorp's Queue Reform Proposal on the grounds it contains insufficient findings of fact and also violates



Docket No. UM 2108  
November 23, 2020  
Page 2

the Public Utility Regulatory Policies Act (PURPA), Oregon law, and PacifiCorp's own tariff.

Whether the Commission should modify its order to allow interconnection customers more time after receiving a cluster study to post a security deposit for the estimated cost of identified Network Upgrades.

Applicable Rule or Law

Oregon Revised Statute (ORS) 756.581 provides:

- (1) After an order has been made by the Public Utility Commission in any proceeding, any party thereto may apply for rehearing or reconsideration thereof within 60 days from the date of service of such order. The commission may grant such a rehearing or reconsideration if sufficient reason therefor is made to appear.
- (2) No such application shall excuse any party against whom an order has been made by the commission from complying therewith, nor operate in any manner to stay or postpone the enforcement thereof without the special order of the commission.
- (3) If a rehearing is granted, the proceedings thereupon shall conform as nearly as possible to the proceedings in an original hearing, except as the commission otherwise may direct. If in the judgment of the commission, after such rehearing and the consideration of all facts, including those arising since the former hearing, the original order is in any respect unjust or unwarranted, the commission may reverse, change or modify the same accordingly. Any order made after such rehearing, reversing, changing or modifying the original determination is subject to the same provisions as an original order.

Oregon Administrative Rule (OAR) 860-001-0720(2) requires that an application for rehearing or reconsideration specify,

- (a) the portion of the challenged order that the applicant contends is erroneous or incomplete;
- (b) the portion of the record, laws, rules, or policy relied upon to support the application;
- (c) the change in the order that the Commission is requested to make;
- (d) how the applicant's requested change in the order will alter the outcome; and

Docket No. UM 2108  
November 23, 2020  
Page 3

(e) one or more of the grounds for rehearing or reconsideration in section (3) of this rule.

Section (3) of the rule provides that the Commission may grant an application for rehearing or reconsideration if the applicant shows that there is:

- (a) New evidence that is essential to the decision and that was unavailable and not reasonably discoverable before issuance of the order;
- (b) A change in the law or policy since the date the order was issued relating to an issue essential to the decision;
- (c) An error of law or fact in the order that is essential to the decision; or
- (d) Good cause for further examination of an issue essential to the decision.

Under OAR 860-001-0720, an application for reconsideration or rehearing is deemed denied if the Commission has not issued an order granting the application by the 60<sup>th</sup> day after filing. If the application is granted, the Commission may affirm, modify, or rescind its prior order or take other appropriate action.

### Analysis

This memorandum addresses two applications for rehearing or reconsideration of Commission Order No. 20-268. This order approved PacifiCorp's request to use a first-ready, first-served method to process interconnection requests that relies on "Cluster" interconnection Studies rather than the first-in-line, first-served method PacifiCorp previously used that relies on serial interconnection studies.<sup>1</sup>

One application is filed jointly by Community Renewable Energy Association (CREA), Oregon Solar Energy Industries Association (OSEIA), and NewSun Energy, LLC (NewSun) (jointly, the "Community Renewable and Solar Advocates" or "CRSA"),<sup>2</sup> and the other is filed jointly by the Renewable Energy Coalition (REC), Northwest &

---

<sup>1</sup> *In the Matter of PacifiCorp d/b/a Pacific Power Application for an Order Approving Queue Reform Proposal*, Docket No. UM 2108, Order No. 20-268.

<sup>2</sup> See Docket No. UM 2108, Application for Rehearing or Reconsideration of Community Renewable Energy Association, Oregon Solar Energy Industries Association, and NewSun Energy LLC (hereinto referred to as "CRSA Application"), October 12, 2020.

Docket No. UM 2108  
November 23, 2020  
Page 4

Intermountain Power Producers Coalition (NIPPC), and Oregon Solar Energy Industries Association (OSEIA) (jointly, the “Interconnection Customer Coalition” or “ICC”).<sup>3</sup>

ICC and CRSA make several legal and policy arguments, which Staff spent considerable time reviewing. Staff reiterates its previously stated position that nearly all of these issues are out of scope for UM 2108 and will be more quickly and transparently addressed in other, existing dockets.

The remainder of this Staff memorandum provides background for these requests and responds to ICC and CRSA’s arguments.

### *Background*

After an informal stakeholder process in 2019, PacifiCorp submitted a Queue Reform Proposal (QRP) with the Federal Energy Regulatory Commission (FERC) on January 31, 2020.<sup>4</sup> The FERC process involved several rounds of notices and responsive pleadings, with involvement from Oregon stakeholders.<sup>5</sup> On April 12, 2020, FERC approved PacifiCorp’s proposal and deficiency letter response, subject to conditions.<sup>6</sup>

Following FERC approval, PacifiCorp submitted an application to include Oregon-jurisdictional interconnection requests in its QRP.

### **Commission Order No. 20-268**

On August 12, 2020, the Commission issued Order No. 20-268 approving PacifiCorp’s interconnection QRP for Oregon-jurisdictional interconnections.<sup>7</sup> Now, interconnection customers will interconnect with PacifiCorp on a first-ready, first-served basis rather than the first-in-time, first-served basis PacifiCorp has used historically. The first-ready, first-served interconnection process is facilitated by use of annual Cluster Studies in which the system impact of interconnecting a generator is studied contemporaneously with the impact of interconnecting other electrically and geographically relevant generators. Once the annual cluster studies are completed and total upgrades necessary to interconnect all participating generators are identified, the generators that

---

<sup>3</sup> See Docket No. UM 2108, The Interconnection Customer Coalition’s Application for Rehearing or Reconsideration of Order No. 20-268, (hereinto referred to as “ICC Application”), October 12, 2020.

<sup>4</sup> See *generally* FERC Docket No. ER20-924-000, PacifiCorp Tariff Filing, January 31, 2020.

<sup>5</sup> The Renewable Energy Coalition (REC), the Community Renewable Energy Association (CREA), the Northwest and Intermountain Power Producers Association (NIPPC), Solar Energy Industries Association (SEIA), Renewable Northwest, and NewSun Energy (NewSun) all applied for, and were granted, intervener status in the FERC proceeding.

<sup>6</sup> See FERC Docket No. ER20-924-000, Order No. 171 FERC ¶ 61,112 (May 12, 2020).

<sup>7</sup> See Docket No. UM 2018, Commission Order No. 20-268, August 19, 2020.

Docket No. UM 2108  
November 23, 2020  
Page 5

are prepared to pay their allocated share of any necessary interconnection facilities and Network Upgrades proceed with a Facilities Study and interconnection agreement.

The first-ready, first-served cluster study process adopted by Commission Order No. 20-268 includes modifications to the serial interconnection process:

- Feasibility Studies, which preceded the System Impact Studies (SIS), are no longer offered. Instead PacifiCorp will provide Interconnection Information Studies prior to submitting an interconnection application (upon request).
- Interconnection customers must apply for interconnection before the close of an annual Cluster Request Window.
- Following the Cluster Request Window, PacifiCorp will hold a 30-day Customer Engagement Window. PacifiCorp will post a draft plan for the Cluster Study and hold a scoping meeting that will assist in the estimation of the potential scope of network upgrade costs given the number and size of other interconnection projects in the Cluster.
- Annual Cluster Studies take the place of serial SIS.
- Generator-specific Facilities Studies are performed after the Cluster Studies, followed by the execution of a generator-specific Interconnection Agreement.

**Requirement to post a security deposit for Network Upgrades**

PacifiCorp's Queue Reform Proposal requires Large Generators to post a financial security equal to 100 percent of assigned Network Upgrades within 30 days of receiving the Cluster System Impact Study. The requirement is concurrent with the execution of a Facilities Study Agreement, which represents a deeper level of commitment by generators that remain in the interconnection queue.<sup>8</sup> In other words, the security deposit requirement is predicated on the assumption that generators that withdraw after this stage (after the period specifically designated for withdrawing from the queue) will cause greater harm to other generators in their Cluster Area and more severely undermine the Cluster Study process.

To balance the burden on generators with the need to minimize withdrawal and restudy, the Commission Order No. 20-268 modified this requirement, limiting the deposit requirement to the lesser of:

---

<sup>8</sup> PacifiCorp Oregon Large Generator Interconnection Procedures, Article 8.1.

Docket No. UM 2108  
November 23, 2020  
Page 6

- 15 percent of the Network Upgrade costs allocated to Interconnection Customer in the most recent Cluster Study Report;
- \$20,000 per megawatt of electrical output of the Large Generating Facility, or the amount of megawatt increase in the generating capacity of each existing Generating Facility as listed by the Interconnection Customer in its Interconnection Request, including any requested modifications thereto; or
- \$7,500,000.

**Requests for reconsideration or rehearing**

CRSA argue reconsideration or rehearing of Order No. 20-268 is appropriate because the order (1) “violates law” because it (a) contains no findings of fact on the issue of the power flow studies, and (b) is supported by insufficient evidence and lacks substantial reasoning to ignore evidence of the impact of the flawed power flow studies; and (2) violates the requirement that each QF be provided the right to create a legally enforceable obligation to sell energy and capacity to PacifiCorp on the date of the QF’s choosing. CRSA also asserts that even if the Commission does not allow reconsideration or rehearing to correct the two alleged errors of law set forth above, the Commission should modify its order to provide QFs a 60-day period execution of the Power Purchase Agreement (PPA) related to the interconnection request to post the security for network upgrades.<sup>9</sup>

ICC specifies that it is “not seeking rehearing or reconsideration of [Order No. 20-268] in regard to any changes to the interconnection process.”<sup>10</sup> Instead the ICC alleges the order is legally flawed because it approves PacifiCorp’s practice of requiring that a QF obtain an interconnection study before the QF is eligible for a draft PURPA PPA. Based on this interpretation of Order No. 20-268, ICC alleges the order is:

- (1) inconsistent with PURPA;
- (2) inconsistent with the OPUC’s own standard for when a legally enforceable obligation is established and the inconsistency is not explained;
- (3) authorizes PacifiCorp to avoid its obligations under the applicable Commission-approved Schedule 37; and

---

<sup>9</sup> CRSA Application, pp. 35-36.

<sup>10</sup> ICC Application, p. 3.

Docket No. UM 2108  
November 23, 2020  
Page 7

- (4) incorrectly overlooks the Commission's obligations to oversee PacifiCorp's compliance with statutory obligations.

ICC asks that at a minimum, the Commission order PacifiCorp to provide executable PPAs and to execute PPAs without first requiring interconnection studies.<sup>11</sup> In addition, the ICC asks the Commission to address other practical matters associated with PURPA contracting and order that PacifiCorp "allow such QFs the right to terminate the PPA within a limited time after receiving the Cluster Study or Facilities Study, or to amend the scheduled commercial operation date to be consistent with the interconnection timeframe in the Cluster Study[.]"<sup>12</sup> and "allow the scheduled commercial operation date to exceed three years after the PPA's Effective Date where necessary based on PacifiCorp's interconnection study."<sup>13</sup>

ICC also asks that the Commission specify its conclusions of law. ICC argues these conclusions of law are necessary because "[w]hen an administrative agency order does not specify the findings of fact or conclusions of law, Oregon courts may remand or void the decision."<sup>14</sup>

#### *Staff Response*

As described above, CRSA and ICC present a range of legal arguments for reconsideration or rehearing and make several other requests, which are summarized in the list below.

#### Legal Arguments for Rehearing and Reconsideration:

- (1) Order contains no findings of fact and ignores evidence related to PacifiCorp's power flow studies; and
- (2) Order is inconsistent with PURPA and the Commission's implementation of PURPA.

#### Requests:

- (1) Modify PacifiCorp's PURPA contracting policies; and
- (2) Require PacifiCorp allow QFs 60 days to post security for Network Upgrades.

---

<sup>11</sup> ICC Application, p. 32.

<sup>12</sup> ICC Application, p. 33.

<sup>13</sup> ICC Application, p. 34.

<sup>14</sup> ICC Application, pp. 1-2.

Docket No. UM 2108  
November 23, 2020  
Page 8

Staff's analysis addresses the arguments first, then responds to the additional requests.

### **Argument #1: Findings of Fact**

CRSA claims Order No. 20-268 is legally flawed because it does not contain adequate findings of fact or substantial reason to justify the Commission's decision. CRSA relies on a misinterpretation of an agency's responsibility in issuing an order in other than a contested case. As the Oregon Supreme Court explained in its 2000 decision in *Norden v. Water Resources Department*, "nothing in the APA directs an agency in other than a contested case proceeding to make a record or to make findings of fact before issuing its order."<sup>15</sup> The Oregon Supreme Court reiterated its holding in a 2004 holding "[u]nder *Norden*, an agency's failure to incorporate findings of fact or conclusions of law into an order in other than a contested case to explain the basis for the order is not a violation of any law."<sup>16</sup>

CRSA relies on ORS 756.558 for its argument the Commission was obligated to make findings of fact. ORS 756.518 specifies that ORS 756.558 is one of many statutes (ORS 756.500 – .610) that "apply to and govern all hearings" before the Commission. ORS 756.558 requires the Commission enter findings of fact and conclusions of law "at the conclusion of taking evidence." CRSA's reliance on ORS 756.558 is misplaced because Order No. 20-268 was not issued after a hearing but after a Public Meeting. The Commission conducts open meetings under the Public Meetings Law codified at ORS 192.610 et seq. This law establishes Oregon's policy that decisions of governing bodies be made through an open process. The law generally requires that (1) the meetings and decisions of public bodies be open to the public; (2) the public has notice of the meetings; and (3) the meetings are accessible to persons wishing to attend.

That ORS 756.558 does not apply to decisions made in a Public Meeting is evident from an examination of the other statutes applicable to "hearings" under ORS 756.518. The other statutes address matters associated with contested case hearings such as requirements for "party" status (ORS 756.525), self-incrimination during testimony (ORS 756.549), taking testimony of any person by deposition upon oral examination or written interrogatories" (ORS 757.538), administering oaths (ORS 756.555), and "taking evidence" (ORS 756.558).<sup>17</sup> If ORS 756.558 applies to orders issued after Public Meetings, the Commission must interpret that all the statutes applicable to hearings under ORS 756.510 apply to public meetings. Under these statutes, participants in public meetings would have right to conduct discovery, subpoena witnesses, offer

---

<sup>15</sup> *Norden v. Water Resources Dept.*, 329 Or. 641, 647 (2000).

<sup>16</sup> *Kucera v. Bradbury*, 337 Or. 384, 406, (2004).

<sup>17</sup> One notable exception is ORS 756.561 governing rehearing or reconsideration of an order issued in "any proceeding." However, ORS 756.518 allows for such exceptions to the limited by specifying that ORS 756.500 - .610 apply to and govern all hearings "except as otherwise provided."

Docket No. UM 2108  
November 23, 2020  
Page 9

testimony, and cross-examine other participants before the Commission could issue an order resolving any matter.

The conclusion that ORS 756.558 does not apply to orders issued after Public Meetings is consistent with Oregon appellate court opinions regarding scope of a circuit court's review of an order in other than contested case under ORS 183.484. Although ORS 183.484 contemplates a record for review in all circumstances and findings of fact based on that record when the circuit court reverses the agency, nothing in the APA directs an agency in other than a contested case proceeding to make a record or to make findings of fact before issuing its order.<sup>18</sup>

The Oregon Supreme Court has explained that “[c]ircuit courts are record-making, fact-finding courts[,] and that “the reference in ORS 183.484 to the “record” is to the record that is made before the circuit court and that the reference to “findings of fact” in ORS 183.484(5) is to the findings that the circuit court makes based on the evidence in that record when it reverses the agency.”<sup>19</sup>

In a proceeding under ORS 183.484 for review of an order other than contested case, review is not limited to the record on which the agency based its decision. Instead, “ORS 183.484 affords the parties the opportunity to develop a record like the one that parties are entitled to develop at an earlier stage in a contested case proceeding.”<sup>20</sup>

Once that record has been developed, the circuit court then reviews to determine “whether the evidence would permit a reasonable person to make the determination that the agency made in a particular case.”<sup>21</sup> “[I]n a case in which expert opinions have been offered on both sides of an issue, it is usually clear that a factfinder has found one or the other more persuasive and substantial evidence and reason will exist to support the findings, without further explanation.”<sup>22</sup>

To the extent CRSA argues the Commission erred by failing to address NewSun's power flow study arguments before reaching its conclusion on PacifiCorp's Queue Reform Proposal, the argument is meritless. The issue before the Commission in UM 2108 was whether Oregon-jurisdictional generator interconnection requests will be processed in the first-ready, first-served Cluster Study process already approved for FERC-jurisdictional interconnections. The Commission was not required to study and

---

<sup>18</sup> See *Oregon Env. Council.*, 307 Or. At 37, 761 P.2d 1322) (APA says little about “that large body of agency actions” that are orders in other than contested cases).

<sup>19</sup> *Norden v. State ex rel. Water Resources Dept.*, *supra*, 329 Or at 647.

<sup>20</sup> *Id.*

<sup>21</sup> *Cervantes v. Department of Human Services*, 295 Or. App. 691, 694-95 (2019), *quoting Norden v. Water Resources Dept.* 329 Or. at 649.

<sup>22</sup> See *Noble v. Oregon Water Resources Department*, 264 Or.App. 110, 123, 330 P.3d 688 (2014).



Docket No. UM 2108  
November 23, 2020  
Page 10

reject other decisions that already approved PacifiCorp's proposal.<sup>23</sup> Nor was the Commission required to consider whether PacifiCorp's power flow study methodology—which PacifiCorp did not propose to change in its transition to a cluster process—should be modified. In fact, this is precisely what FERC concluded when NewSun asked FERC to direct PacifiCorp to change how it conducts its power flow studies:

[W]e find that [FERC] was not required to direct PacifiCorp to improve its network models, as PacifiCorp did not propose OATT revisions addressing its network models. Under FPA section 205, the Commission is limited to considering whether the proposal before it is just and reasonable and not unduly discriminatory or preferential, including whether a proposed deviation is consistent with or superior to the pro forma OATT, not whether an alternative approach might also be just and reasonable.<sup>24</sup>

#### **Argument #2: Consistency with PURPA**

CRSA and ICC make multiple assertions that the Commission's order violates PURPA because it prevents qualifying facilities from creating a legally enforceable obligation to sell energy and capacity to PacifiCorp on the date of the QF's choosing. They argue this because PacifiCorp's PURPA contracting practices require QFs to obtain a completed System Impact Study (now referred to as a Cluster System Impact Study) before they are eligible to receive a draft power purchase agreement. The coalitions' assertions are wholly without merit because the Commission made no determination regarding PacifiCorp's PURPA contracting process.

In its order, the Commission approved modifications to PacifiCorp's interconnection procedures as outlined in PacifiCorp's Queue Reform Proposal, with some modifications. PacifiCorp's implementation of PURPA was not at issue in PacifiCorp's application. By approving PacifiCorp's application to change how PacifiCorp process requests for interconnection, the Commission neither approved nor disapproved PacifiCorp's practice of requiring that QF's obtain a completed System Impact Study as a condition of eligibility for a draft power purchase agreement (PPA). Accordingly, the coalitions' assertions that Order

---

<sup>23</sup> See Docket No. UM 2108, Staff Report for the August 11, 2020 Public Meeting, August 3, 2020, p. 12.

<sup>24</sup> *In re PacifiCorp*, 173 FERC 61,016, P 20 (*Order Denying Clarification and Addressing Arguments Raised on Rehearing*), citing *Cal. Indep. Sys. Operator Corp.*, 128 FERC par. 61, 265, at P 21 (2009) (“[T]he issue before the Commission is whether the [California Independent System Operator, Inc.’s] proposal is just and reasonable and not whether the proposal is more or less reasonable than other alternatives”).

Docket No. UM 2108  
November 23, 2020  
Page 11

No. 20-268 is flawed because the Commission approved PacifiCorp's PURPA contracting process is factually incorrect and meritless.

Staff acknowledges that Staff analyzed stakeholders' concerns with the intersection of PacifiCorp's PURPA contracting process and Queue Reform Proposal in its Public Meeting Memorandum. Staff did so to address the stakeholders' claims that PacifiCorp's proposal should be rejected because of its alleged adverse impact on QFs, not to make arguments to the Commission on whether the Commission should approve or disapprove PacifiCorp's PURPA contracting practice. The coalitions should not be allowed to bootstrap their arguments made in this docket regarding adoption of PacifiCorp's Queue Reform Proposal into allegations the Commission's order adopting PacifiCorp's Queue Reform Proposal related to interconnection violates PURPA or Oregon law regarding PURPA implementation. Whether PacifiCorp appropriately requires QFs to obtain a completed interconnection study prior to eligibility for a draft PPA was not at issue in the underlying Public Meeting process and should not be at issue now.

**Request #1 Modify PacifiCorp's PURPA contracting policies**

Even if the QFs' complaints about PacifiCorp's PURPA contracting policies have merit, Staff does not think it would have been appropriate to address these PURPA claims in this docket concerning PacifiCorp's interconnection process.<sup>25</sup> Instead, they are properly addressed in Docket No. UM 2000 or AR 631, or a Complaint under ORS 756.500 brought against PacifiCorp.

**Request #2: Security for Network Upgrades**

While the Commission reduced the requirement for Oregon large generators to post a financial security for Network Upgrades, CRSA argues that the requirement is likely to result in withdrawals and undermine the Cluster Study process. CRSA argues that, if Network Upgrade costs for a QF generator are very high, it is not possible to secure that level of financing without a PPA.<sup>26</sup>

The Commission clearly understood the QFs' concerns with the deposit, but also considered the interests of all generators in an efficient interconnection process when imposing the security deposit requirement. The Commission's resolution of this issue is not a legal error. However, there may be good cause to reconsider this requirement for purposes of the Transition Cluster Study.

---

<sup>25</sup> CRSA Application, p. 33.

Docket No. UM 2108  
November 23, 2020  
Page 12

On November 4, 2020, PacifiCorp posted its Transition Cluster interconnection queue and Transition Cluster Areas. When the Commission approved PacifiCorp's Queue Reform Proposal, there were over 50 Oregon generators in queue, totaling more than 5,000 MW. Staff's review indicates that the Transition Cluster Areas containing Oregon generators contain only 17 projects, all of which are QFs.<sup>27</sup> With a cleared-out queue and the opportunity for cost sharing, the remaining QF generators may not face overly burdensome Network Upgrades. Conversely, if certain Oregon QFs face high Network Upgrade costs in the Transition Cluster, only these QFs, likely represented by CRSA, will be impacted by withdrawals. These outcomes will not be known until after the Cluster Study System Impact results are issued in the first and second quarter of 2021.

Under these circumstances, Staff concludes there may be good cause to change the security deposit requirement for the Transition Cluster. This will allow the Commission to better understand the extent to which QFs that receive additional time to post a security will withdrawal and harm other participants in their Cluster Area. Accordingly, Staff recommends that the Commission waive the current requirement for Oregon Large Generators to post a financial security deposit for Network Upgrades until 90 days following the receipt of the Cluster System Impact Study. Staff proposes to monitor the extent to which this change from 30 days to 90 days results in late-stage withdrawals and can make a recommendation to continue this practice or revert to the Commission's original direction.

### Conclusion

CRSA and ICC have not shown that the Commission's order was legally flawed or that there is good cause to reconsider the Commission's order. Because it will only impact the QFs likely represented by CRSA, Staff finds that there may be good cause to waive the security deposit requirement for Oregon Large Generators for the Transition Cluster.

### **PROPOSED COMMISSION MOTION:**

Grant the application for reconsideration filed by Community Renewable Energy Association, Oregon Solar Industries Association, and Northwest and Intermountain Power Producers Coalition with respect to the Network Upgrade security deposit requirement for the Transition Cluster Study as proposed by Staff and otherwise deny the request for reconsideration or rehearing.

---

<sup>27</sup> With the exception of a single 60 MW California solar plus storage project near the California-Oregon border that may not be a QF.

Docket No. UM 2108  
November 23, 2020  
Page 13

Deny the Application for rehearing or reconsideration filed by the Renewable Energy Coalition, Oregon Solar Energy Industries Association, and Northwest and Intermountain Power Producers Coalition.

UM 2108 Request for Rehearing or Reconsideration

**ATTACHMENT C**

**AFFIDAVIT OF JOHN R. LOWE**

**IN THE COURT OF APPEALS OF THE  
STATE OF OREGON**

In the Matter of:

RENEWABLE ENERGY  
COALITION, NORTHWEST &  
INTERMOUNTAIN POWER  
PRODUCERS COALITION,  
COMMUNITY RENEWABLE  
ENERGY ASSOCIATION and  
OREGON SOLAR ENERGY  
INDUSTRIES ASSOCIATION,

Petitioners,

v.

THE OREGON PUBLIC UTILITY  
COMMISSION,

Respondent,

and

PACIFICORP,

Applicant-Respondent

Oregon Public Utility Commission  
Docket No. UM 2108

CA No. A\_\_\_\_\_.

**AFFIDAVIT OF JOHN R. LOWE  
IN SUPPORT OF PETITION FOR JUDICIAL REVIEW**

I, John R. Lowe, being first duly sworn on oath, depose and say:

1. My name is John R. Lowe. I am a natural person, over the age of majority, of sound mind and in all respects competent to testify in judicial

proceedings.

2. I am the executive director of the Renewable Energy Coalition (“REC”), which is one of the Petitioners in the above-captioned proceeding.

3. REC is an unincorporated trade association that is comprised of nearly 40 members who own and operate nearly 50 qualifying facilities or are attempting to develop new qualifying facilities under the Public Utility Regulatory Policies Act (“PURPA”) in Oregon, Idaho, Washington, Utah, Montana, and Wyoming. The Renewable Energy Coalition’s members include irrigation districts, water and waste management districts, corporations, small utilities, and individuals with an interest in selling renewable energy to utilities – who, absent PURPA, may have no viable mechanism to develop and sell the output of renewable energy projects.

4. To promote renewable energy development and adoption of policies that will support such development, REC regularly participates in administrative and judicial proceedings regarding the mandatory purchase provisions of the PURPA, which in Oregon are implemented by the Public Utility Commission (“PUC”).

5. On or about June 15, 2020, PacifiCorp filed its Application for an Order Approving Queue Reform Proposal (“QRP” and “QRP Application”) in PUC Docket No. UM 2108, which requested that the PUC make changes to its rules and policies regarding the process, terms, and conditions under which

PacifiCorp must interconnect to its electrical system the small renewable energy facilities proposing to sell energy to PacifiCorp under PURPA. The filings made and orders issued in the PUC Docket No. UM 2108 are available at <https://apps.puc.state.or.us/edockets/docket.asp?DocketID=22455>.

6. PacifiCorp's QRP Application proposed to change PacifiCorp's interconnection study process for most state-jurisdictional generators from a serial queue approach, under which interconnection customers are supposed to receive interconnection study results on a first-come, first-served basis at any time, to a Cluster Study approach where study results are only available at most on an annual basis. In the final orders on review, Order No. 20-268 and Order No. 20-465, the PUC adopted PacifiCorp's proposal with certain modifications.

7. REC, along with other renewable energy advocates, opposed PacifiCorp's QRP Application in part on the ground that its adoption in full would be harmful to renewable energy development. REC advocated positions other than those adopted in the PUC's orders, including: by filing written comments jointly with other organizations in opposition to PacifiCorp's application on or about July 17, 2020, and reply comments on or about August 7, 2020; by presenting oral argument through counsel at the PUC's public meetings where the application was addressed; and by filing an application for rehearing or reconsideration of Order No. 20-268 jointly with other organizations on or about October 12, 2020.



8. REC also petitioned the PUC for intervenor status in the proceeding below on or about July 20, 2020, but the PUC has not ruled on REC's request for intervenor status.

9. REC's membership includes entities that are actively engaged in developing renewable energy facilities intended to be operated as qualifying facilities under PURPA in Oregon interconnecting to, and selling power to, PacifiCorp. If left intact without modification, I believe that the PUC's orders on review will adversely impact the members of REC that develop renewable energy facilities in Oregon by authorizing new hurdles and requirements to interconnecting such facilities to, and selling energy to, PacifiCorp.

10. In addition to the harm to REC's members engaged in renewable energy development, I expect that REC will itself be directly and adversely affected by the PUC's orders in this proceeding because the orders conflict with REC's organizational mission and purpose to promote renewable energy development in Oregon. The orders also could materially diminish successful development of renewable energy projects in areas of Oregon where REC and its members are active, which would adversely impact REC's membership base and reduce revenue available to REC to perform its functions.

I hereby declare that the above statements are true to the best of my knowledge and belief. I understand they are made for use in court and I am subject

to penalty for perjury.

I signed this the 28<sup>th</sup> day of January 2021.

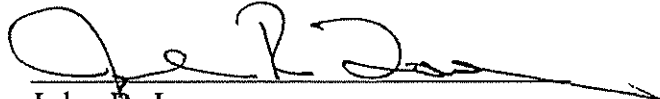
  
John R. Lowe

SUBSCRIBED AND SWORN to before me this 28<sup>th</sup> day of January 2021.

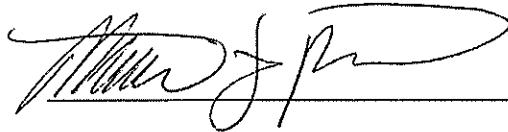
  
\_\_\_\_\_

Notary Public for the State of Oregon

Residing at 11084 SW Barnes rd

Portland OR

My Commission expires 01/16/2024

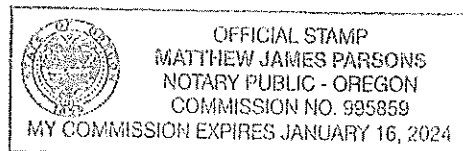

**ATTACHMENT C-1**

**UM 2108 REC PETITION TO INTERVENE**

**BEFORE THE PUBLIC UTILITY COMMISSION**

**OF OREGON**

**UM 2108**

In the Matter of

PACIFICORP d/b/a PACIFIC POWER

Application for an Order Approving Queue  
Reform Proposal.

RENEWABLE ENERGY  
COALITION'S  
PETITION TO INTERVENE

Pursuant to ORS § 756.525 and OAR § 860-001-0300(2), the Renewable Energy Coalition (the "Coalition") petitions the Oregon Public Utility Commission (the "Commission") to intervene and appear with full party status. In support of this petition to intervene, Coalition provides the following information:

The name and address of Coalition is:

Renewable Energy Coalition  
John Lowe  
PO Box 25576  
Portland, OR 97298  
Telephone: (503) 717- 5375  
E-Mail: jravenesanmarcos@yahoo.com

Sanger Law, PC will represent Coalition in this proceeding. All documents relating to these proceedings should be served on the following persons at the addresses listed below:

John Lowe  
Renewable Energy Coalition  
PO Box 25576  
Portland, OR 97298  
Telephone: (503) 717- 5375  
Fax: (503) 717- 5092  
jravenesanmarcos@yahoo.com

Irion Sanger  
Sanger Law, PC  
1041 SE 58th Place  
Portland, OR 97215  
Telephone: (503) 756-7533  
Fax: (503) 334-2235  
irion@sanger-law.com

Joni Sliger  
Sanger Law, PC  
1041 SE 58th Place  
Portland, OR 97215  
Telephone: (425) 894-3680  
Fax: (503) 334-2235  
joni@sanger-law.com

The Coalition was established in 2009 and is comprised of nearly forty members who own and operate over fifty qualifying facilities (“QFs”) or are attempting to develop new QF projects in Oregon, Idaho, Washington, Utah, Montana and Wyoming. The Coalition has participated in numerous regulatory proceedings intended to promote appropriate interconnection procedures, competitive markets, PURPA, renewable energy, and diversity of generation ownership, including all the recent major proceedings regarding interconnections, qualifying facility contract and rate eligibility. The Coalition’s members include QFs that intend to, or already have engaged in PacifiCorp’s interconnection study processes.

The Coalition has a substantial interest in this proceeding because the Commission’s Order regarding whether to approve PacifiCorp’s Queue Reform Proposal will have an effect on its members that plan to, or already, engage in PacifiCorp’s interconnection and power purchase agreement (“PPA”) contracting processes. The Commission’s decision has the potential to burden the Coalition’s members with increased interconnection study fees and deposits, as well as increased wait-times to

engage in the PPA execution process. The Coalition has additional interests in PacifiCorp's cost-sharing proposals, its proposed treatment of QFs 10 MW or greater, and the effect this proposal will have on existing QFs, which PacifiCorp has yet to explain with specificity. As these issues and potentially several other unresolved issues discourage qualifying facility growth and ability to interconnect with PacifiCorp, the Coalition petitions to intervene to gain a full understanding of how this Queue Reform Proposal will ultimately affect its members.

The Coalition's intervention will assist the Commission in resolving the issues and will not unreasonably broaden the issues, burden the record, or delay this proceeding. Finally, the Coalition's interest is not adequately represented by any other party in this proceeding.

WHEREFORE, the Coalition respectfully requests that the Commission grant its petition to intervene with full party status in this proceeding and to appear and participate in all matters as may be necessary and appropriate; and to present evidence, call and examine witnesses, cross-examine witnesses, present argument, and to otherwise fully participate in the proceedings.

Dated this 20th day of July 2020.

Respectfully submitted,

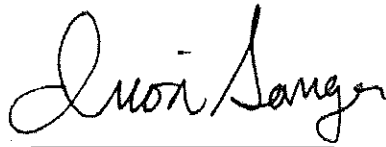
A handwritten signature in black ink that reads "Irion Sanger". The signature is written in a cursive style with a horizontal line underneath the name.

Irion Sanger  
Sanger Law, PC  
1041 SE 58th Place  
Portland, OR 97215  
Telephone: (503)756-7533  
Fax: (503)334-2235  
irion@sanger-law.com

Of Attorneys for the Renewable Energy Coalition

**ATTACHMENT D**

**AFFIDAVIT OF SPENCER GRAY**



**IN THE COURT OF APPEALS OF THE  
STATE OF OREGON**

In the Matter of:

RENEWABLE ENERGY  
COALITION, NORTHWEST &  
INTERMOUNTAIN POWER  
PRODUCERS COALITION,  
COMMUNITY RENEWABLE  
ENERGY ASSOCIATION and  
OREGON SOLAR ENERGY  
INDUSTRIES ASSOCIATION,

Petitioners,

v.

THE OREGON PUBLIC UTILITY  
COMMISSION,

Respondent,

and

PACIFICORP,

Applicant-Respondent

Oregon Public Utility Commission  
Docket No. UM 2108

CA No. A\_\_\_\_\_.

**AFFIDAVIT OF SPENCER GRAY  
IN SUPPORT OF PETITION FOR JUDICIAL REVIEW**

I, Spencer Gray, being first duly sworn on oath, depose and say:

1. My name is Spencer Gray. I am a natural person, over the age of majority, of sound mind and in all respects competent to testify in judicial

proceedings.

2. I am the executive director of the Northwest & Intermountain Power Producers Coalition (“NIPPC”), which is one of the Petitioners in the above-captioned proceeding.

3. NIPPC is a Washington-based trade association. Organized as a nonprofit corporation, NIPPC’s members include independent power producers who develop and operate power plants, as well as power marketers and independent transmission companies. NIPPC’s members have collectively invested billions of dollars in existing generation resources in the United States and also have renewable and thermal projects in advanced development in the Northwest, some of which are in Oregon.

4. To promote competitive power markets and adoption of policies that will support such markets, NIPPC regularly participates in administrative and judicial proceedings, including proceedings regarding the mandatory purchase provisions of the PURPA, which in Oregon are implemented by the Public Utility Commission (“PUC”).

5. On or about June 15, 2020, PacifiCorp filed its Application for an Order Approving Queue Reform Proposal (“QRP” and “QRP Application”) in PUC Docket No. UM 2108, which requested that the PUC make changes to its rules and policies regarding the process, terms, and conditions under which

PacifiCorp must interconnect to its electrical system the small renewable energy facilities proposing to sell energy to PacifiCorp under PURPA. The filings made and orders issued in the PUC Docket No. UM 2108 are available at <https://apps.puc.state.or.us/edockets/docket.asp?DocketID=22455>.

6. PacifiCorp's QRP Application proposed to change PacifiCorp's interconnection study process for most state-jurisdictional generators from a serial queue approach, under which interconnection customers are supposed to receive interconnection study results on a first-come, first-served basis at any time, to a Cluster Study approach where study results are only available at most on an annual basis. In the final orders on review, Order No. 20-268 and Order No. 20-465, the PUC adopted PacifiCorp's proposal with certain modifications.

7. NIPPC, along with other renewable energy advocates, opposed PacifiCorp's QRP Application in part on the ground that its adoption in full would be harmful to independent power producers who operate qualifying facilities under PURPA. NIPPC advocated positions other than those adopted in the PUC's orders, including: by filing written comments jointly with other organizations in opposition to PacifiCorp's application on or about July 17, 2020, and reply comments on or about August 7, 2020; by presenting oral argument through counsel at the PUC's public meetings where the application was addressed; and by filing an application for rehearing or reconsideration of Order No. 20-268 jointly

with other organizations on or about October 12, 2020.

8. NIPPC also petitioned the PUC for intervenor status in the proceeding below on or about July 20, 2020, but the PUC has not ruled on NIPPC's request for intervenor status.

9. NIPPC's membership includes entities that are actively engaged in developing renewable energy facilities intended to be operated as qualifying facilities under the Public Utility Regulatory Policies Act ("PURPA") in Oregon interconnecting to, and selling power to, PacifiCorp. If left intact without modification, I believe that the PUC's orders on review will adversely impact the members of NIPPC that develop qualifying facilities in Oregon by authorizing new hurdles and requirements to interconnecting such facilities to, and selling energy to, PacifiCorp.

10. In addition to the harm to NIPPC's members engaged in renewable energy development, I expect that NIPPC will itself be directly and adversely affected by the PUC's orders in this proceeding because the orders conflict with NIPPC's organizational mission and purpose to promote competitive power markets in Oregon. The orders also could materially diminish successful development of non-utility owned facilities in areas of Oregon where NIPPC and its members are active, which would adversely impact NIPPC's membership base and reduce revenue available to NIPPC to perform its functions.

I hereby declare that the above statements are true to the best of my knowledge and belief. I understand they are made for use in court and I am subject to penalty for perjury.

I signed this the 28th day of January 2021.

*Spencer Gray*

\_\_\_\_\_  
Spencer Gray

SUBSCRIBED AND SWORN to before me this \_\_\_\_ day of January 2021.

See Attached Certificate

\_\_\_\_\_  
Notary Public for the State of Oregon

Residing at

\_\_\_\_\_

My Commission expires \_\_\_\_\_



JURAT

State/County of TEXAS )

and  of the County of Travis )

On 01/28/2021, before me, Margaret Kaplan,  
*Date Notary Name*

the foregoing instrument was subscribed and sworn (or affirmed) before me by:

Spencer Gray

*Name of Affiant(s)*

Proved to me on the basis of satisfactory evidence: **OR --**

Proved to me on the basis of satisfactory evidence: the oath of \_\_\_\_\_ -- OR --  
*of Credible Witness*

Proved to me on the basis of satisfactory evidence: driver\_license  
*Type of ID Presented*

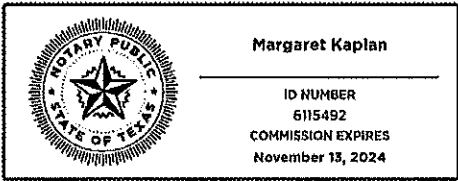

Notarized online using audio-video communication

Notary Public Margaret Kaplan

Notary Name: Margaret Kaplan

My Commission Expires 6115492

Notary Public for 11/13/2024

*Notarized online using audio-video communication*

**DESCRIPTION OF ATTACHED DOCUMENT**

Title or Type of Document: Affidavit

Document Date: 01/28/2021

Number of Pages (including notarial certificate): 7

**ATTACHMENT D-1**

**UM 2108 NIPPC PETITION TO INTERVENE**



**BEFORE THE PUBLIC UTILITY COMMISSION  
OF OREGON**

**UM 2108**

In the Matter of	)	
	)	
PACIFICORP d/b/a PACIFIC POWER	)	NORTHWEST AND
	)	INTERMOUNTAIN POWER
Application for an Order Approving Queue	)	PRODUCERS COALITION
Reform Proposal.	)	PETITION TO INTERVENE
_____	)	

Pursuant to ORS § 756.525 and OAR § 860-001-0300(2), the Northwest and Intermountain Power Producers Coalition (“NIPPC”) petitions the Oregon Public Utility Commission (the “Commission”) to intervene and appear with full party status. In support of this petition to intervene, NIPPC provides the following information:

The name and address of NIPPC is:

Northwest and Intermountain Power Producers Coalition  
Spencer Gray  
Executive Director  
P.O. Box 504  
Mercer Island, WA 98040  
Email: sgray@nippc.org

Sanger Law, PC will represent NIPPC in this proceeding. All documents relating to these proceedings should be served on the following persons at the addresses listed below:

Spencer Gray  
Executive Director  
P.O. Box 504  
Mercer Island, WA 98040  
sgray@nippc.org

Irion Sanger  
Sanger Law, PC  
1041 SE 58th Place  
Portland, OR 97215  
Telephone: (503) 756-7533  
Fax: (503) 334-2235  
irion@sanger-law.com

Joni Sliger  
Sanger Law, PC  
1041 SE 58th Place  
Portland, OR 97215  
Telephone: (425) 894-3680  
Fax: (503) 334-2235  
joni@sanger-law.com

NIPPC is a trade association whose members and associate members include independent power producers active in the Pacific Northwest and Western energy markets.<sup>1</sup> The purpose of NIPPC is to represent the interests of its members in developing rules and policies that help achieve a competitive electric power supply market in the Pacific Northwest.

NIPPC's members include independent power producers which may bid into PacifiCorp's 2020 all source request for proposal. NIPPC is committed to fair and open-access transmission service, cost effective power sales, consumer choice in their energy supply, and fair, competitive power markets in the northwest and adjacent markets.

NIPPC has a substantial interest in this proceeding because the Commission's Order regarding whether to approve PacifiCorp's Queue Reform Proposal will have an effect on its members that plan to, or already, engage in PacifiCorp's interconnection and power purchase agreement ("PPA") contracting processes. The Commission's decision has the potential to burden NIPPC's members with increased interconnection study fees

---

<sup>1</sup> NIPPC's members include: Calpine, Constellation Energy, Cycle, EASE LLC, Ecoplexus, EDF Renewable Energy, EDP Renewables, Geronimo Energy, Invenergy LLC, Morgan Stanley, NewSun Energy, Obsidian Renewables, Perennial Power Holdings, Shell Energy North America, Sierra Pacific Industries, TLS Capital, TransAlta Energy Marketing, and Tyr Energy.

and deposits, as well as increased wait-times to engage in the PPA execution process. NIPPC has additional interests in PacifiCorp's cost-sharing proposals, its proposed treatment of qualifying facilities ("QFs") 10 MW or greater, and the effect this proposal will have on existing QFs, which PacifiCorp has yet to explain with specificity. As these issues and potentially several other unresolved issues discourage qualifying facility growth, NIPPC petitions to intervene to gain a full understanding of how this Queue Reform Proposal will ultimately affect its members.

NIPPC has participated in numerous regulatory proceedings intended to promote competitive markets, utility resource procurement, requests for proposals, renewable energy, and diversity of generation ownership, including all the recent major proceedings regarding utility requests for proposals and competitive bidding, including the establishment of the current competitive bidding rules and PacifiCorp recent requests for proposals. NIPPC's intervention will assist the Commission in resolving the issues and will not unreasonably broaden the issues, burden the record, or delay this proceeding. Finally, NIPPC's interest is not adequately represented by any other party in this proceeding.

WHEREFORE, NIPPC respectfully requests that the Commission grant its petition to intervene with full party status in this proceeding and to appear and participate in all matters as may be necessary and appropriate; and to present evidence, call and examine witnesses, cross-examine witnesses, present argument, and to otherwise fully participate in the proceedings.

Dated this 4th day of August 2020.

Respectfully submitted,

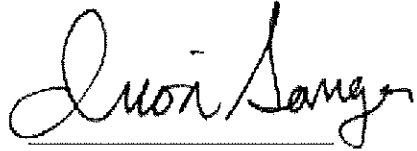
A handwritten signature in black ink that reads "Irion Sanger". The signature is written in a cursive style with a horizontal line underneath the name.

Irion Sanger  
Sanger Law, PC  
1041 SE 58th Place  
Portland, OR 97215  
Telephone: (503)756-7533  
Fax: (503)334-2235  
irion@sanger-law.com

Of Attorneys for the Northwest and Intermountain  
Power Producers Coalition

**ATTACHMENT E**

**AFFIDAVIT OF LES PERKINS**

**IN THE COURT OF APPEALS OF THE  
STATE OF OREGON**

In the Matter of:

RENEWABLE ENERGY  
COALITION, NORTHWEST &  
INTERMOUNTAIN POWER  
PRODUCERS COALITION,  
COMMUNITY RENEWABLE  
ENERGY ASSOCIATION and  
OREGON SOLAR ENERGY  
INDUSTRIES ASSOCIATION,

Petitioners,

v.

THE OREGON PUBLIC UTILITY  
COMMISSION,

Respondent,

and

PACIFICORP,

Applicant-Respondent

Oregon Public Utility Commission  
Docket No. UM 2108

CA No. A\_\_\_\_\_.

**AFFIDAVIT OF LES PERKINS  
IN SUPPORT OF PETITION FOR JUDICIAL REVIEW**

I, Les Perkins, being first duly sworn on oath, depose and say:

1. My name is Les Perkins. I am a natural person, over the age of

majority, of sound mind and in all respects competent to testify in judicial proceedings.

2. I am the Board Chair of the Community Renewable Energy Association (“CREA”), which is one of the Petitioners in the above-captioned proceeding.

3. CREA is an intergovernmental association organized under Oregon Revised Statutes Chapter 190. CREA’s organizational purpose is to promote policies that will result in development of small-scale community renewable energy projects in Oregon, which in turn will promote local economic development opportunities in Oregon’s rural counties. In addition to its policy advocacy, CREA provides technical expertise for developers, landowners and counties where renewable energy projects are under consideration.

4. CREA is comprised of several Oregon counties and local governments which provide active participation through their county commissioners, including Sherman County, Wasco County, Gilliam County, Harney County, Hood River County, Morrow County, Wheeler County, Curry County, and Wallowa County.

5. CREA also has members that are actively engaged in development and/or operation of renewable energy projects, including irrigation districts that develop and/or operate small hydropower facilities, developer businesses actively

developing and/or operating renewable energy facilities, such as solar and wind facilities, as well as individuals and non-profit organizations who have interest in a viable community renewable energy sector for Oregon.

6. To promote small-scale renewable energy development and adoption of policies that will support such development, CREA regularly participates in administrative and judicial proceedings regarding the mandatory purchase provisions of the Public Utility Regulatory Policies Act of 1978 (“PURPA”), which in Oregon are implemented by the Public Utility Commission (“PUC”) to require utilities to purchase electric energy from certain renewable energy facilities, referred as “qualifying facilities.”

7. On or about June 15, 2020, PacifiCorp filed its Application for an Order Approving Queue Reform Proposal (“QRP” and “QRP Application”) in PUC Docket No. UM 2108, which requested that the PUC make changes to its rules and policies regarding the process, terms, and conditions under which PacifiCorp must interconnect to its electrical system the small renewable energy facilities proposing to sell energy to PacifiCorp under PURPA. The filings made and orders issued in the PUC Docket No. UM 2108 are available at <https://apps.puc.state.or.us/edockets/docket.asp?DocketID=22455>.

8. PacifiCorp’s QRP Application proposed to change PacifiCorp’s interconnection study process for most state-jurisdictional generators from a serial



queue approach, under which interconnection customers are supposed to receive interconnection study results on a first-come, first-served basis at any time, to a Cluster Study approach where study results are only available at most on an annual basis. In the final orders on review, Order No. 20-268 and Order No. 20-465, the PUC adopted PacifiCorp's proposal with certain modifications.

9. CREA, along with other qualifying facility advocates, opposed PacifiCorp's QRP Application in part on the ground that its adoption in full would be harmful to renewable energy development. CREA advocated positions other than those adopted in the PUC's orders, including: by filing written comments jointly with other organizations in opposition to PacifiCorp's application on or about July 17, 2020, and reply comments on or about August 7, 2020; by presenting oral argument through counsel at the PUC's public meetings where the application was addressed; and by filing an application for rehearing or reconsideration of Order No. 20-268 jointly with other organizations on or about October 12, 2020.

10. CREA also petitioned the PUC for intervenor status in the proceeding below on or about October 12, 2020, but the PUC has not ruled on CREA's request for intervenor status. A true and correct copy of the Petition to Intervene is attached to this affidavit as Exhibit A.

11. CREA's membership includes entities that are actively engaged in

developing renewable energy facilities intended to be operated as qualifying facilities under PURPA in Oregon interconnecting to, and selling power to, PacifiCorp. If left intact, I believe that the PUC's orders on review will adversely impact the members of CREA that develop renewable energy facilities in Oregon by authorizing new hurdles and requirements to interconnecting such facilities to, and selling energy to, PacifiCorp.

12. In addition to the harm to CREA's members engaged in renewable energy development, I expect that CREA will itself be directly and adversely affected by the PUC's orders in this proceeding because the orders conflict with CREA's organizational mission and purpose to promote renewable energy development in Oregon. The orders also could materially diminish successful development of renewable energy projects in areas of Oregon where CREA and its members are active, which would adversely impact CREA's membership base, reduce revenue available to CREA to perform its functions, and reduce demand for CREA's services for developers, landowners and counties where renewable energy projects are under consideration.

I hereby declare that the above statements are true to the best of my knowledge and belief. I understand they are made for use in court and I am subject to penalty for perjury.

I signed this the 28 day of January 2021.

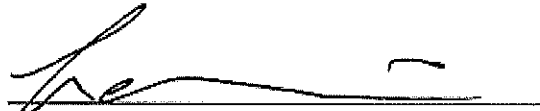
  
Les Perkins

SUBSCRIBED AND SWORN to before me this 28 day of January 2021.

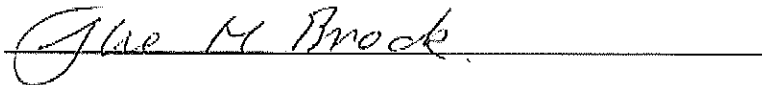

Notary Public for the State of Oregon

Residing at

Hood River

My Commission expires 11-19-21



**ATTACHMENT E-1**

**UM 2108 CREA PETITION TO INTERVENE**

BEFORE THE PUBLIC UTILITY COMMISSION

OF OREGON

UM 2108

In the Matter of

PACIFICORP d/b/a PACIFIC POWER

Application for an Order Approving Queue Reform Proposal.

PETITION TO INTERVENE OF THE  
COMMUNITY RENEWABLE ENERGY  
ASSOCIATION

Pursuant to ORS 756.525 and OAR 860-001-0300, the Community Renewable Energy Association (“CREA”) hereby respectfully petitions the Public Utility Commission of Oregon (“OPUC” or “Commission”) to grant CREA intervenor status in this proceeding. In support of this Petition, CREA states as follows:

1. The name and address of CREA is:

Community Renewable Energy Association  
c/o Brian Skeahan  
PMB 409  
18160 Cottonwood  
Sunriver, OR 97707  
Email: [Brian.skeahan@community-renewables.org](mailto:Brian.skeahan@community-renewables.org)

2. CREA will be represented in this proceeding by Peter J. Richardson (OSB No. 066687) and Gregory M. Adams (OSB No. 101779), of the law firm Richardson Adams, PLLC.

3. All documents relating to this proceeding should be served on the following persons:

Gregory M. Adams (OSB No. 101779)  
Richardson Adams, PLLC  
515 N. 27<sup>th</sup> Street  
Boise, Idaho 83702  
Telephone: 208-938-2236  
Fax: 208-938-7904  
greg@richardsonadams.com

Brian Skeahan  
PMB 409  
18160 Cottonwood  
Sunriver, OR 97707  
Telephone: 360-431-5072  
brian.skeahan@community-renewables.org

4. CREA is an Oregon Rev. Stat. Ch. 190 intergovernmental association. *See* ORS 190.003- 190.118. CREA consists of local governments seeking to promote locally-owned renewable energy projects for all forms of renewable generation recognized in Oregon’s Renewable Portfolio Standard (biomass, geothermal, hydropower, ocean thermal, solar, tidal, wave, wind and hydrogen). CREA is comprised of several Oregon counties which provide active participation through their county commissioners, including Sherman, Wasco, Gilliam, Harney, Hood River, Morrow, Polk, Union, Wheeler, Curry, and Wallowa. In addition to these counties, CREA’s current membership includes the Mid-Columbia Council of Governments, Columbia Gorge Community College, and 25 irrigation districts, businesses, individuals and non-profit organizations who have interest in a viable community renewable energy sector for Oregon, many of whom are actively engaged in developing renewable energy facilities intended to be operated as QFs in Oregon.

5. In its efforts to establish a viable market in Oregon for community-scale renewable energy projects, CREA has intervened or otherwise actively participated in numerous dockets at the Commission regarding Oregon’s implementation of the mandatory purchase provisions of the Public Utility Regulatory Policies Act of 1978 (“PURPA”). CREA has also

intervened or actively participated in proceedings before the Federal Energy Regulatory Commission (“FERC”) that affect Oregon qualifying facilities (“QFs”).

6. Because the outcome of this proceeding may affect the ability for community renewable energy projects to interconnect to and sell their output to Oregon utilities as QFs, CREA has a direct and substantial interest in this matter. CREA has been an active participant in this proceeding through the public hearing process. Although the Commission has not yet issued a contested case notice in this proceeding or granted any party intervenor status in this proceeding, CREA makes this request to ensure that it is granted intervenor status at such time as the Commission may rule on petitions to intervene.

7. CREA’s participation in this docket will assist the Commission in resolving the issues and will not unreasonably burden the record, delay the proceedings or broaden the issues.

8. Because no other party can adequately represent CREA’s interests in this proceeding, CREA respectfully requests that the Commission grant this Petition to Intervene.

RESPECTFULLY SUBMITTED this 12th day of October 2020.

RICHARDSON ADAMS, PLLC

/s/ Gregory M. Adams  
Gregory M. Adams (OSB No. 101779)  
515 N. 27<sup>th</sup> Street  
Boise, Idaho 83702  
Telephone: 208-938-2236  
greg@richardsonadams.com

Of Attorneys for the Community Renewable  
Energy Association

**ATTACHMENT F**

**AFFIDAVIT OF ANGELA CROWLEY-KOCH**



**IN THE COURT OF APPEALS OF THE  
STATE OF OREGON**

In the Matter of:

RENEWABLE ENERGY  
COALITION, NORTHWEST &  
INTERMOUNTAIN POWER  
PRODUCERS COALITION,  
COMMUNITY RENEWABLE  
ENERGY ASSOCIATION and  
OREGON SOLAR ENERGY  
INDUSTRIES ASSOCIATION,

Petitioners,

v.

THE OREGON PUBLIC UTILITY  
COMMISSION,

Respondent,

and

PACIFICORP,

Applicant-Respondent

Oregon Public Utility Commission  
Docket No. UM 2108

CA No. A\_\_\_\_\_.

**AFFIDAVIT OF ANGELA CROWLEY-KOCH  
IN SUPPORT OF PETITION FOR JUDICIAL REVIEW**

I, Angela Crowley-Koch, being first duly sworn on oath, depose and say:

1. My name is Angela Crowley-Koch. I am a natural person, over the age of majority, of sound mind and in all respects competent to testify in judicial

proceedings.

2. I am the executive director of the Oregon Solar Energy Industries Association (“OSEIA”), which is one of the Petitioners in the above-captioned proceeding.

3. OSEIA is an Oregon-based trade association founded in 1981 to promote clean, renewable, solar technologies. OSEIA members include businesses, non-profit groups, and other solar industry stakeholders. OSEIA provides a unified and respected voice of the solar industry and focuses exclusively on the solar value chain; from workforce development to permitting, advocacy, policy, and regulation for residential, commercial, community, and utility scale solar projects on the local, state and regional level.

4. To promote renewable energy development and adoption of policies that will support such development, OSEIA regularly participates in administrative and judicial proceedings, including those regarding the mandatory purchase provisions of the Public Utilities Regulatory Policy Act (“PURPA”), which in Oregon are implemented by the Public Utility Commission (“PUC”).

5. On or about June 15, 2020, PacifiCorp filed its Application for an Order Approving Queue Reform Proposal (“QRP” and “QRP Application”) in PUC Docket No. UM 2108, which requested that the PUC make changes to its rules and policies regarding the process, terms, and conditions under which

PacifiCorp must interconnect to its electrical system the small renewable energy facilities proposing to sell energy to PacifiCorp under PURPA. The filings made and orders issued in the PUC Docket No. UM 2108 are available at <https://apps.puc.state.or.us/edockets/docket.asp?DocketID=22455>.

6. PacifiCorp's QRP Application proposed to change PacifiCorp's interconnection study process for most state-jurisdictional generators from a serial queue approach, under which interconnection customers are supposed to receive interconnection study results on a first-come, first-served basis at any time, to a Cluster Study approach where study results are only available at most on an annual basis. In the final orders on review, Order No. 20-268 and Order No. 20-465, the PUC adopted PacifiCorp's proposal with certain modifications.

7. OSEIA, along with other renewable energy advocates, opposed PacifiCorp's QRP Application in part on the ground that its adoption in full would be harmful to renewable energy development. OSEIA advocated positions other than those adopted in the PUC's orders, including: by filing written comments jointly with other organizations in opposition to PacifiCorp's application on or about July 17, 2020, and reply comments on or about August 7, 2020; by presenting oral comments at the PUC's public meetings where the application was addressed; and by filing an application for rehearing or reconsideration of Order No. 20-268 jointly with other organizations on or about October 12, 2020.

8. OSEIA's membership includes entities that are actively engaged in developing renewable energy facilities intended to be operated as qualifying facilities under PURPA in Oregon interconnecting to, and selling power to, PacifiCorp. If left intact without modification, I believe that the PUC's orders on review will adversely impact the members of OSEIA that develop renewable energy facilities in Oregon by authorizing new hurdles and requirements to interconnecting such facilities to, and selling energy to, PacifiCorp.

9. In addition to the harm to OSEIA's members engaged in renewable energy development, I expect that OSEIA will itself be directly and adversely affected by the PUC's orders in this proceeding because the orders conflict with OSEIA's organizational mission and purpose to promote renewable energy development in Oregon. The orders also could materially diminish successful development of renewable energy projects in areas of Oregon where OSEIA and its members are active, which would adversely impact OSEIA's membership base and reduce revenue available to OSEIA to perform its functions.

I hereby declare that the above statements are true to the best of my knowledge and belief. I understand they are made for use in court and I am subject to penalty for perjury.

State of: Oregon  
County of: Multnomah

I signed this the 28 day of January 2021.

  
\_\_\_\_\_  
Angela Crowley-Koch

SUBSCRIBED AND SWORN to before me this 28 day of January 2021.

  
\_\_\_\_\_  
Notary Public for the State of Oregon

Residing at  
114 NE 55th Ave. Portland OR

My Commission expires 4/16/2024

